



BRIEF GUIDE TO THE BUDDIPOLE ANTENNA SYSTEM

by David Haycock, KI6AWR





Brief Guide to the Buddipole Antenna System

by David Haycock, KI6AWR





BRIEF GUIDE TO THE BUDDIPOLE ANTENNA SYSTEM

by David Haycock, KI6AWR

A BRIEF GUIDE TO THE BUDDIPOLE SYSTEM

Welcome to the Buddipole antenna system, a unique, capable and adaptable antenna system for a wide range of applications. The light weight and modular design makes the antenna particularly suited for portable applications, but it is also well suited for other fixed situations where space is limited.

What makes the Buddipole exciting for me is that the Buddipole is so much more than a simple antenna; it is a great tool for exploring antenna theory. In addition to being an excellent portable antenna, it is the only “antenna lab” that I know of.

The modular design of the Buddipole system means that the antenna can be easily transported and quickly assembled and disassembled. Modularity brings a couple of different benefits.

First, it means that when the antenna is disassembled the individual parts are less bulky and easy to carry. Second, parts of the antenna are interchangeable providing the opportunity to build many different types of antennas.

Why did I spend my hard-earned spare time writing this? Well, while Chris (W6HFP) and Budd (W3FF) are spending their time designing and building this ever expanding line of antenna products, as well as providing legendary customer support, they have little time to devote to writing new materials. I want to keep them busy coming up with new products for us to play with, so I believe my investment in time is well spent.

My intention is to show that the Buddipole is more than a simple well-made antenna, it is a system that is highly adaptable and can grow as your needs and interests change.

There are other well made single purpose antennas on the market, but no others that I know of with the flexibility of the Buddipole. I hope that you have as much fun with it as I have.

73,

David, KI6AWR

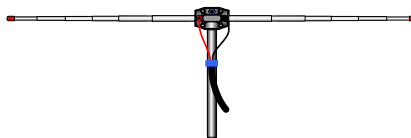

A BRIEF GUIDE TO THE BUDDIPOLE SYSTEM.....	1
1. THE BUDDIPOLE TREASURE CHEST	3
1.1 VERSATEE	3
1.2 ANTENNA MOUNTS	4
1.2.1 MAST.....	4
1.2.2 BUDDIPOLE TRIPOD.....	4
1.3 HORIZONTAL ELEMENTS.....	5
1.3.1 ANTENNA ARM.....	5
1.3.2 TELESCOPIC WHIPS.....	6
1.3.3 SHOCK CORD WHIPS.....	7
1.4 VERTICAL ELEMENTS	8
1.4.1 VERSATEE VERTICAL.....	8
1.5 LOADING COILS.....	9
1.5.1 STANDARD COILS.....	9
1.5.2 LOW BAND COIL.....	9
1.6 BEYOND THE BASICS	10
1.6.1 ROTATING ARM KIT (RAK).....	10
1.6.2 TRIPLE RATIO SWITCH BALUN (TRSB).....	11
1.6.3 WIRE ASSEMBLY	12
1.6.4 COUNTERPOISE WIRE ADAPTER (CWA).....	12
1.6.5 IT ADAPTER (ITA).....	13
1.6.6 IT COLLAR (ITC)	13
1.6.7 YAGI MAST ADAPTER (YMA).....	14
1.6.8 CAPACITY HAT.....	15
2 COMBINATIONS.....	16
2.1 THE BUDDIPOLE.....	16
2.2 THE BUDDIPOLE DELUXE.....	16
2.3 THE MINI BUDDIPOLE	16
2.4 THE BUDDISTICK	16
2.5 THE BUDDISTICK DELUXE PACKAGE	17
2.6 PACKAGE COMPARISON	17
3 PUTTING IT ALL TOGETHER	18
3.1 BUDDIPOLE HORIZONTAL DIPOLE.....	18
3.1.1 HORIZONTAL DIPOLE TUNING (40m to 10m)	18
3.1.2 HORIZONTAL DIPOLE TUNING (6m and 2m).....	19
3.2 BUDDIPOLE VERSATEE VERTICAL.....	20
3.3 BUDDIPOLE 2 ELEMENT HORIZONTAL YAGI.....	22
3.4 OTHER CONFIGURATIONS	23

1. THE BUDDIPOLE TREASURE CHEST

The Buddipole and Buddipole Deluxe are a collection of items from the Buddipole system of parts that come packaged in a handy carrying case. They include the major parts needed to build a number of basic types of antennas including the classic horizontal dipole and the very simple and useful Buddipole Versatee vertical. It is easy to assume that the Buddipole system is simply a horizontal dipole, but in reality that is just a starting point. The pieces that constitute the basic Buddipole system can be used to build several types of antennas, and with a few additional items many more can be assembled. This section introduces you to the items in the Buddipole accessory list, which can be used to create different configurations of antennas.

1.1 VERSATEE

The Versatee is the heart of the Buddipole system. It is both the mechanical support system for the antenna elements as well as the connection point for the feed line.

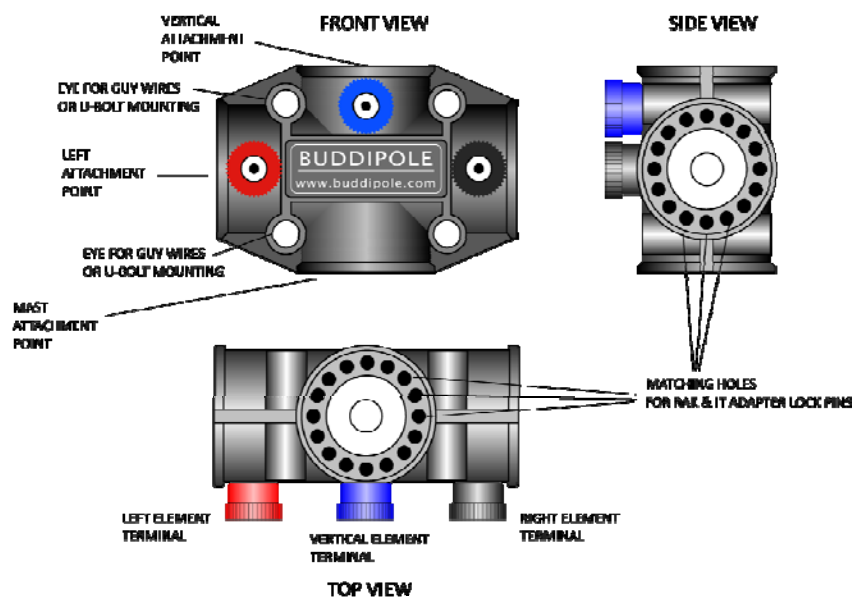

The red, black and blue terminals are connection points for the left, right and vertical elements which we will review in detail later. The Versatee is the key to the modularity of the Buddipole antenna system. There are several types of elements and masts that can be used with this one central piece.

1.2 ANTENNA MOUNTS

1.2.1 MAST

There are four types of masts that can be attached directly to the Versatee.

The Center Tee Adapter, or “CTA”, allows a “painter’s pole” purchased from a hardware store to be adapted to the Versatee thread size (1/2” NPT).

The 10 ft and 18 ft telescopic masts can be conveniently used with the Buddipole tripod to make a self-supporting structure. There are various adapters used to thread into the bottom of the Versatee (see illustration). The latest versions of these adapters are secured to the mast using a side set screw (instead of the older method which used epoxy and which were non-removable).

These newer adapters also have an internal 3/8” x 24 thread on top which will allow an IT adapter (ITA) to be connected directly to the mast without using the Yagi Mast Adapter (YMA). This is really useful if you are constructing a Yagi. More on this later.

The shockcord masts (SCM) are a lightweight alternative to the telescopic masts. These masts are available in 2 lengths: 8’ and 13’ (when extended). The SCM’s rely on guy lines to keep the antenna supported.

Finally, you can even use U-bolts through the holes in the Versatee to secure it to other types of masts. The distance between the holes is 1.25” center to center.

1.2.2 BUDDIPOLE TRIPOD

The Buddipole tripod works with the Buddipole masts. The legs are telescopic improving the stability of the tripod and adding additional height to the mast when fully extended.

The mast can be guyed or the tripod stabilized by using an auger or weights. Ignore this important point and it will take only one short gust to topple the whole antenna, automatically entering you into the “Broken Whip Club”.

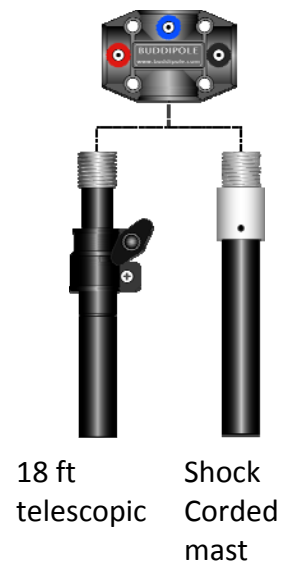
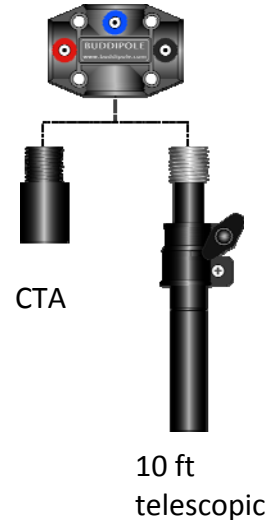

1.3 HORIZONTAL ELEMENTS

1.3.1 ANTENNA ARM

The Versatee provides the ability to construct a horizontal or vertically polarized antenna. The most familiar of those is the horizontal dipole.

The horizontal dipole is created by attaching an antenna arm to each side of the Versatee. The standard Buddipole comes with a pair of 22 inch lightweight aluminum arms and a pair of the standard telescopic whips (66 inches (1.68m) long when extended, 12 inches when collapsed).

The antenna arms have the strength to support the weight of the loading coils and the telescopic or shock corded whips (including the capacity hats).

The smaller 11 inch arms are sometimes more convenient to carry and can be coupled together to make the equivalent of the longer 22 inch arm. The smaller arms come standard with the Buddistick (2 per antenna) or Mini-Buddipole antennas (4 per antenna).

Both sizes of the antenna arms have a male 3/8 inch x 24 TPI threaded end and a female threaded end at the opposite end of the arm.

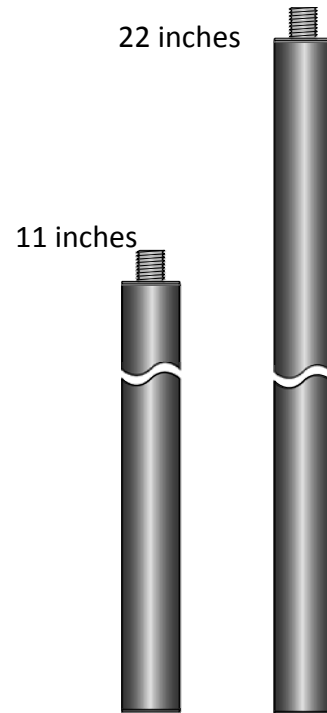

1.3.2 TELESCOPIC WHIPS

In addition to the standard length whips, there are the long telescopic whips, “featherweight” telescopic whips and shock cord whips.

Why so many choices of whips?

The standard whips extend to 66 inches (1.7m) and are very useful on all bands from 40m to 2m.

The longer whips extend to 114 inches (2.9m) and because they increase the physical size of the antenna so much they reduce the amount of inductance needed for any given band. This increases bandwidth and improves efficiency, particularly on the lower bands. They are long enough to make a full size horizontal dipole for the 10m band.

The shock cord whips are more robust and quick to deploy, although it involves a slightly different approach to tuning. They can also be used with the capacity hats, offering some improvements in performance (see 1.6.8 for more details). More about the shock cord whips can be found in section 1.3.3 .

The standard and long telescopic whips and the shock cord whips are all equipped with 3/8th inch-24 TPI threaded bases which will attach directly to the Versatee or any coil.

The featherweight whip extends to 72 inches (1.8m) and has a 1/4 inch x 20 TPI threaded end. This is intended for homebrew applications, and is perfect for the “Homebrew” Buddipole made from PVC parts (see www.qsl.net/w3ff for more details).

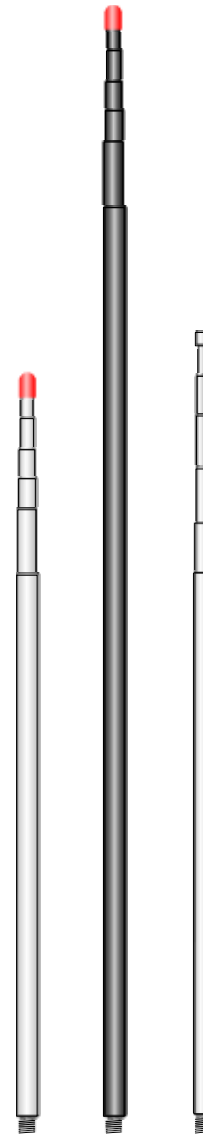

1.3.3 SHOCK CORD WHIPS

Unlike telescopic whips, the shock corded whips are not adjustable in length. They are available, however, in several different lengths as shown in the table below.

Number of sections	Extended length	Application
3	64 inches (1.63 m)	H or V
4	85 inches (2.16 m)	H or V
5	106 inches (2.69 m)	H or V
6	127 inches (3.23 m)	V only
7	148 inches (3.76 m)	V only

Each section of the whip is a rigid hollow tube, and the sections are connected together by a rugged elastic cord running through the center. Each section drops into a brass connector of the adjacent section and locks securely into place under the tension provided by the internal cord. All sizes of shock corded whips are equipped with a 3/8th inch x 24 TPI threaded base.

The shock cord whips are more robust than the telescopic whips, and can be used with the capacity hats, offering some improvements in performance (see 1.6.8 capacity hats).

The smallest shock cord whip is the three section whip and the extended length is about 64 inches. This is shown in the extended form and collapsed form in the illustration to the right.

Because the shock cord whips are fixed in length, tuning must be accomplished by using the loading coil tap positions only. A separate manual is available which shows the coil settings for the various ham bands based on the number of sections of the shock cord whips.

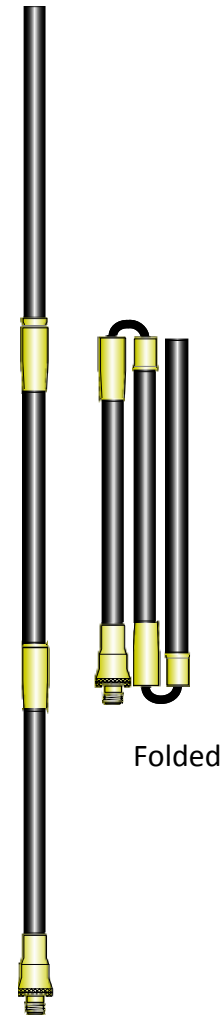

1.4 VERTICAL ELEMENTS

1.4.1 VERSATEE VERTICAL

The Versatee can support horizontal elements, or a single vertical element screwed directly into the top of the Versatee. The thread on the top insert is the same as all the others on the Versatee and will accept the antenna arms, whips or loading coils.

Attaching a quarter wavelength of wire to the side connection of the Versatee and sloping that to just above ground level creates a type of vertically polarized dipole providing an effective vertical antenna without the need for a more extensive radial ground system. For more details see 3.2 (Versatee vertical) later in this document.

Another method to create a vertical element is to use the Rotating Arm Kit (RAK) in conjunction with the Versatee. This is illustrated in the figure to the right.

The RAK adapter can be rotated and locked into fixed positions on both sides of the Versatee supporting not only vertical configurations but “V” or sloping configurations. For more details see 1.6.1 later in this document.

Another interesting vertical arrangement can be created for the higher frequency bands. By using a Rotating Arm Adapter on each side of the Versatee, two closely spaced vertical elements can be supported forming a type of JPole. As an example this provides a simple and convenient way to make an omni-directional antenna for 6m.

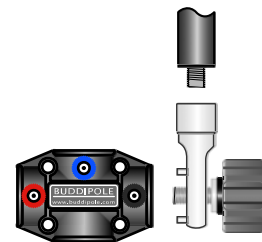
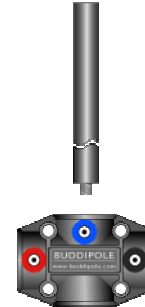

Versatee with RAK

1.5 LOADING COILS

1.5.1 STANDARD COILS

The Buddipole is typically set up as a shortened antenna which simply means that its physical length is shorter than its effective electrical length. Loading coils are an essential part of reducing the size of an antenna.

A full size horizontal half wave dipole on 40 meters is close to 20m (65 ft) wide. The loading coils enable the antenna to be a lot smaller than the full size version making it more practical to carry and set up.

The standard set of loading coils provided with the Buddipole is designed to provide operation on all bands from 40m to 10m. Both coils are required for a horizontal dipole, but only one coil is required for a vertical.

A different amount of inductance is required for each band which requires a different tap setting on each coil. The tap settings differ from band to band as indicated in the Buddipole documentation (see 3.1.1 for details). The coils are provided with coil clip terminals which are secured onto the coil windings. The jumper wire has a miniature banana plug which inserts directly into the coil clip terminal. To simplify changing bands you can place coil clips on different places on the coil and change bands merely by moving the plug from one clip to another.

1.5.2 LOW BAND COIL

Operating on the lower frequency bands requires a coil with more inductance. The low band coil is physically larger than the standard coils and provides about three times the inductance. It has the same thread type so it is completely compatible with the other Buddipole components.

This coil is ideal for use in making low frequency band antennas such as the compact 80m vertical.



1.6 BEYOND THE BASICS

1.6.1 ROTATING ARM KIT (RAK)

Elements do not have to be either vertical or horizontal. There are many configurations that have offsets or sloping elements and these are readily accomplished by using the Rotating Arm Kit in conjunction with the Versatee. A top view of the RAK adapter is shown in the adjacent figure.

The left, top, and right ends of the Versatee adapter are designed to work with the RAK. Holes arranged around the center fixing point allow the RAK to be set at any of sixteen different angles.

The RAK has a 3/8th inch x 24 TPI threaded female end that will accept an antenna arm or whip.

The side view (adjacent) shows the two locking pins that engage with the matching holes at each end of the Versatee. The RAK is held in place by the locking knob.

Top View

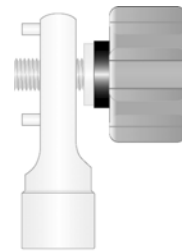

Side View

1.6.2 TRIPLE RATIO SWITCH BALUN (TRSB)

A useful addition to the Buddipole system is a variable ratio balun. This type of balun increases the low feedpoint impedance of an antenna so that it is a better match to the transceiver. The TRSB should be connected directly to the Versatee using the adapter cable supplied with the TRSB.

Although the TRSB is not an essential item, it has a couple of very important benefits. It operates as a balun, and also operates as a feed point impedance transformer.

The true balun action of the TRSB significantly reduces the interaction between the coax and antenna making the tuning more predictable.

The ability for the TRSB to transform a low feed point impedance up to the 50 ohm is very important and particularly useful for a small HF band antenna like the Buddipole.

The TRSB has a three position switch allowing for quick selection between impedance transforming of 1:1, 2:1 or 4:1. For example if the antenna impedance is around 25 ohms, this can be efficiently transformed to 50 ohms by using the 2:1 setting. When the feedpoint impedance is close to 50 ohms, set the switch to 1:1 and you will get the benefits of the balun without spoiling your already acceptable feed point impedance.

When the Buddipole is used without a TRSB, the antenna is set up as an Off Center-Fed (OCF) Dipole which raises the feedpoint impedance to close to 50 ohms. This is accomplished by having different coil settings and whip lengths on each side of the antenna. When using a Buddipole with the TRSB, this asymmetric setup is no longer required so the left and right halves of the antenna can be set up identically.

The TRSB is required for the “Low Band Vertical” antenna on 60 and 80m. Information on this setup is available in a separate manual available on the Buddipole website.

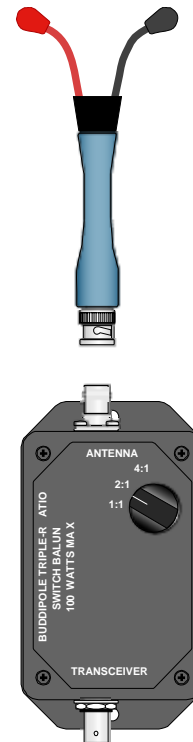

1.6.3 WIRE ASSEMBLY

The wire assembly consists of a glass-filled nylon winder filled with 32 ft of thin insulated wire for use as a counterpoise (see Versatee vertical 3.2).

For low band use there is a long wire version of the WA that has 66 ft of wire.

In use, one end of the wire is attached to the Versatee using the Counterpoise Wire Adapter (see below). Wire is then unwound from the winder until the required length of wire has been spooled off. The wire should then be tucked under one of the wire hooks. Because wire remaining on the winder does not affect antenna tuning, fine tuning can be accomplished by paying out additional wire or winding it back onto the winder.



1.6.4 COUNTERPOISE WIRE ADAPTER (CWA)

The Counterpoise Wire Adapter is provided with the Wire Assembly. It is screwed into either end of the Versatee and securely tightened using the bar section that is pinned through the central threaded piece. The counterpoise wire (see above) can then be connected underneath the terminal.

The counterpoise is used when the antenna is configured as a Versatee vertical (see section 3.2).

Top view

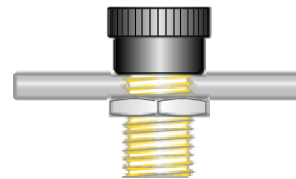
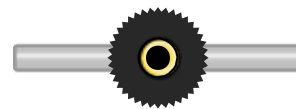

Side view

1.6.5 IT ADAPTER (ITA)

Higher performance antennas can be built by adding elements to a basic dipole. The IT adapter is a useful component to create a boom or a parasitic element.

The IT adapter has a 3/8th inch x 24 TPI female thread at each end that will accept an antenna arm or whip.

The IT adapter can be attached directly to the mast (using a mast adapter), as part of a boom, or to the end of the boom as part of a parasitic element. Take a look at the example later in this document (section 3.3).

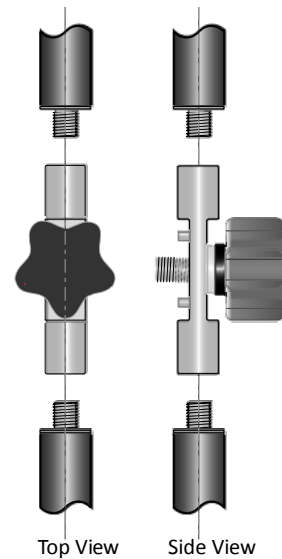

1.6.6 IT COLLAR (ITC)

An antenna arm makes an excellent boom for a small Yagi. The IT collar is used to clamp the arm in position so that an element of a Yagi can be retained at a specific angle without rotating in the wind.

The fixed pins in the collar locate into the Versatee or IT adapter and the set screw in the collar clamps the collar in place on the antenna arm. This prevents the antenna arm from unscrewing and misaligning the elements (the "windmill" effect).

The illustration to the right shows the IT collar used to lock the boom of a Yagi to the Versatee (which is used to support the driven elements). See section 3.3 for an example of how the IT collar can also be used with the IT adapter to form a reflector or director.

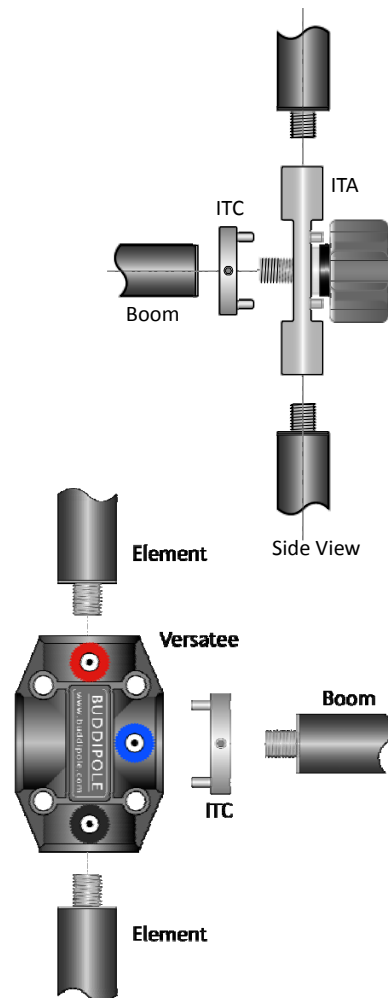

1.6.7 YAGI MAST ADAPTER (YMA)

Classic single element antennas such as the horizontal dipole or vertical can be constructed by attaching the Versatee directly to the top of the mast. The elements are then attached to the Versatee creating a horizontal or vertically polarized antenna.

When constructing an antenna such as a 2 element Yagi the boom needs to be connected to the mast and the Versatee connected at the end of the boom to create the center of the driven element. A simple way to achieve this is use the IT adapter. The latest masts allow the IT connector to screw directly into the central hole in the top of the mast. Earlier versions of the mast require the use of the Yagi Mast Adapter which converts from the male thread at the top of the mast to a female thread suitable for the IT adapter (ITA). The illustration to the right shows how the ITA attaches to the YMA.

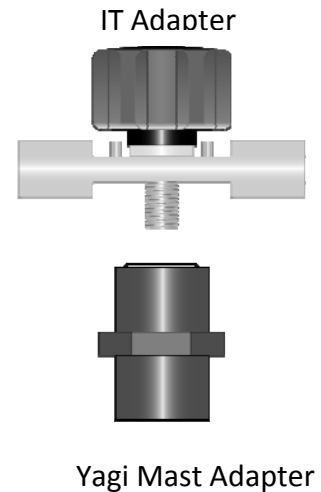

1.6.8 CAPACITY HAT

A loading coil provides compensation to a shortened antenna so that it can be made to resonate.

Another way to compensate for the shortened length of a small antenna is to add capacitance.

This means that the antenna can be resonated using coil settings with less inductance and this provides a few additional benefits. Lower inductance means lower coil losses, and it also reduces the antenna Q which increases the useful bandwidth. Both of these factors are especially important on the lower frequency bands.

The Capacity Hat consists of a central hub which is attached to the end of a shock cord whip. Five evenly spaced spokes fold out from the central hub and lock in the fully extended position. A perimeter wire is permanently attached providing additional capacitance. When folded it occupies only 22 inches x 1.5 inches and is very lightweight.

Capacity hats can be attached to the ends of the shock cord whips in the both vertical and horizontal configurations.

Although the capacity hat is very light in weight it is not advisable to use it with more than a four section shock corded whip. To get more length for a vertical antenna you should use an antenna arm for the lower section of the antenna and add the shock corded whip above that.

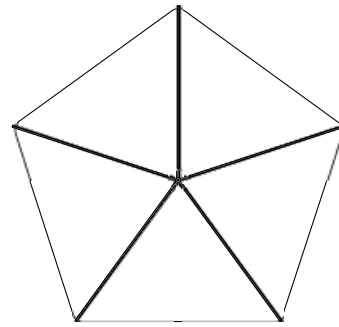

Capacity Hat
Top View
(Vertical antenna)

End View
(Horizontal Antenna)

2 COMBINATIONS

The individual items are available as combinations of items providing a complete antenna system.

2.1 THE BUDDIPOLE

The basic Buddipole kit provides all the components needed to assemble a loaded horizontal dipole or a loaded vertical (when purchased with wire counterpoise) for all bands from 40m to 2m. It includes the VersaTee, two 22" antenna arms, two standard high Q coils, two standard stainless steel whips, one set of 3 coil clips, and a 25 ft length of coaxial feed cable with built-in choke balun designed to plug straight into the Versatee. The radio end of the coax is terminated in a BNC connector and a BNC/ PL-259 adapter is supplied so you can use either type of connector.

The antenna comes in a black packcloth bag, and is placed with the manuals into a black polypropylene carrying case. Total length of the case is 28 inches. Shipping weight is a little over 4 pounds. The only extra things that you will need are a mast and a way to support the mast. These can be purchased separately or as part of the Buddipole Deluxe package (see below).

2.2 THE BUDDIPOLE DELUXE

The Buddipole Deluxe Package includes the contents of the standard Buddipole plus the 8 ft. mast, large tripod, the Rotating Arm Kit (RAK), extra coil clips, and an extra stainless steel whip. These are provided together with a 24" Cordura deluxe bag with carrying strap, a copy of the "Effective Use of Buddipole Configurations" report, and the manual for operation. You can swap out the short mast for the longer mast (18' when extended and it collapses to 37") and the long bag (40" long) for an additional charge (see the drop down box on the Buddipole Deluxe Package page).

2.3 THE MINI BUDDIPOLE

To optimize portability even more, the Mini Buddipole is provided with four 11" antenna arms instead of the standard two 22" arms. This makes it smaller to pack. Performance is identical to the standard dipole. This one is packaged in a portfolio bag with slots and pockets for each of the various components. You can carry it in a briefcase. The standard telescopic mast will not fit in this bag, but the shock cord mast will fit in perfectly. See <http://www.youtube.com/buddipole> for a short video on the setup.

2.4 THE BUDDISTICK

This is essentially one half of the Buddipole mounted vertically. It includes two black 11" antenna arms, a standard coil, a standard stainless steel telescoping whip, two coil clips, a mounting kit which consists of a mounting plate, an adapter that has 3/8 by 24 inch threads on top and a place for user-supplied coax to thread onto an SO-239 on the

bottom. A hole in the aluminum mounting plate allows you to fit the plate over a one-quarter inch sized stud (standard on all camera tripods and accessories). A length of 31 feet poly-coated wire is provided for a single radial that should be elevated from the feedpoint and sloped down to a minimum of two feet off the ground. The Buddistick comes in a very classy portfolio bag for carrying.

2.5 THE BUDDISTICK DELUXE PACKAGE

The same items as provided with the Buddistick, but with three coil clips instead of two clips, the mini-tripod or portable vertical antenna clamp (your choice) for e.g. setting up on a picnic table or balcony railing , and an extra telescopic whip.

2.6 PACKAGE COMPARISON

Because the items of the Buddipole family are interchangeable, you can easily upgrade your Buddipole system. The list below shows the items included in each of the Buddipole packages.

ITEM	Buddipole	Buddipole Deluxe	Mini Buddipole	Buddistick	Buddistick Deluxe
Versatee	1	1	1	-	-
11 inch antenna arm	-	-	4	2	2
22 inch antenna arm	2	2	-	-	-
Standard Whips	2	3	2	1	2
Standard Red Coil (includes 3 coil clips)	1	1	1	1	1
Standard Black Coil (includes 3 coil clips)	1	1	1	-	-
Set of spare coil clips (3 clips)	-	1	-	-	-
Set of spare coil clips (2 clips)	-	-	-	-	1
25 ft portable coax assembly	1	1	1	-	-
50 ft portable coax assembly	-	option	option	-	-
31 ft radial wire (counterpoise)	-	1	-	1	-
Thermoplastic case	1	-	-	-	-
Carrying bag (23 inch)	-	1	-	-	-
Carrying bag (38 inch)	-	option	-	-	-
Portfolio bag	-	-	1	1	1
10 ft Mast	-	1	-	-	-
18 ft Mast	-	option	-	-	-
Buddipole Tripod	-	1	-	-	-
Rotating Arm Kit (RAK)	-	1	-	-	-
Buddistick mounting plate	-	-	-	1	1
Mini tripod or vertical antenna clamp (choose one)	-	-	-	-	1

3 PUTTING IT ALL TOGETHER

The question is often asked – what type of antenna is a Buddipole? The next few examples illustrate that there is no simple answer given all the different possible configurations. The Buddipole is a system of parts that can be connected together to make a large number of different antenna types, from the basic dipole to directional antennas with either vertical or horizontal polarization, to other unique combinations. The three listed here represent only a glimpse of the many different types that can be built. An opportunity for another “how to” guide perhaps? Yes, it’s in the works!

3.1 BUDDIPOLE HORIZONTAL DIPOLE

This should perhaps be known as the Buddipole Classic. This is the most basic type of horizontal antenna, yet despite its simplicity it can be very effective.



The illustration above shows a Buddipole horizontal dipole for the high frequency bands. This is the standard arrangement, although other configurations are also possible. This set up is convenient and the coil tap settings and whip lengths for this standard configuration are well documented for all bands in the Buddipole manual.

3.1.1 HORIZONTAL DIPOLE TUNING (40m to 10m)

Loading coils are needed whenever the physical length of the dipole is less than one half of a wavelength. Changing bands requires the position of the taps on both coils to be changed and the length of the whips may also need to be trimmed. Settings for the 40m through 10m bands are shown in the following table. This table applies to the configuration with 22 inch arms connected to the Versatee and the coils mounted to the outer end of the arms. The standard whips are attached to the outer end of the coils as shown in the figure above.

BAND	RED COIL SIDE		BLACK COIL SIDE	
	WHIP LENGTH (Num sections)	TAP POSITION (turns from whip end)	WHIP LENGTH (Num sections)	TAP POSITION (turns from whip end)
40m	5.5	NONE	5	NONE
30m	6	23	6	19
20m	6	10	6	14
17m	4.5	10	6	6
15m	6	4	6	6
12m	6	2	6	4
10m	5	2	6	2

One of the common questions regarding setup of the Buddipole Horizontal Dipole is why the coils are not identical and why the tap positions are different between the two coils. This is because an antenna that is physically smaller than a half wavelength has a lower feedpoint impedance than its bigger half wave cousin. Also, when the height of the antenna is less than one quarter wavelength, the effects of the ground under the antenna may further affect the feedpoint impedance. Having a low feedpoint impedance increases the SWR, but a simple way to resolve this is to make the dipole asymmetrical. This has the effect of electrically moving the feedpoint of the antenna away from the center and so increasing the feed point impedance. A dipole setup this way is known as an “Off Center Fed Dipole” (OCFD).

Having more turns on the coil on one side of the antenna than the other side creates an OCFD and when correctly set gives you a good SWR. Notice that on the 40m band, neither coil has a tap connected, but this does not mean that the coils have the same inductance. When no taps are connected the inductance of the red coil is about 28 μ H and the inductance of the black coil is about 26 μ H giving us the required asymmetry.

3.1.2 HORIZONTAL DIPOLE TUNING (6m and 2m)

The physical length of the dipole is the tip to tip length, so when you use the standard whips in conjunction with the 22 inch antenna arms this is about 179 inches (4.55 meters). This is more than enough to make a full size half wave dipole for the 6m or 2m bands. In fact a full size dipole can be made with just the whips, not requiring the use of coils or the antenna arms.

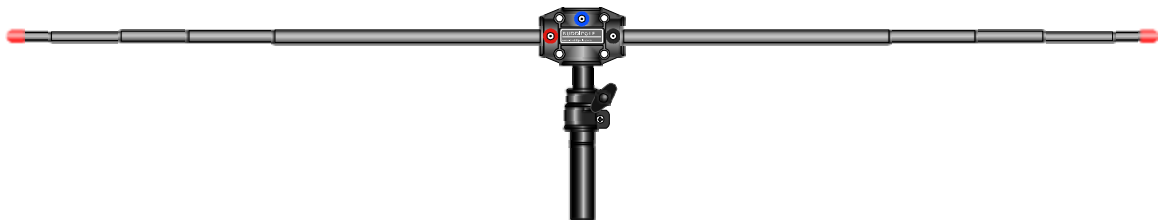

BAND	LEFT SIDE WHIP LENGTH (Num sections)	RIGHT SIDE WHIP LENGTH (Num sections)
6m	4.5	4.5
2m	1 section +2 inches	1 section +2 inches

3.2 BUDDIPOLE VERSATEE VERTICAL

The Versatee Vertical is a very practical vertically polarized antenna. Although it looks a little like a quarter wave vertical, it is in fact a form of vertical dipole in disguise. The confusing aspect of the antenna is that the upper and lower parts of the antenna do not look the same and they are not in line. It is also confusing because the lower part is sometimes misrepresented as a “radial”. Confusion here is due to the fact that some vertical groundplane antennas use radial wires to provide a ground system and that is the more common use of the word radial.

The upper part of the antenna looks like the top half of a center loaded half wave vertical dipole. This is the conventional part of the antenna. The unique part of this configuration is the lower part which consists of a sloped wire which is one quarter of a wavelength long. The sloping wire (counterpoise) can be conveniently formed using the Wire Assembly (see 1.6.3).

The sloping wire is not a part of the ground system, but is a significant contributor to the RF energy radiated by the antenna.

In this configuration a 22 inch antenna arm is mounted to the top of the Versatee and a “red” loading coil mounted to the end of the arm. A fully extended whip is mounted to the top of the coil. The counterpoise wire (lower radiator) is connected to one side of the Versatee using a Counterpoise Wire Adapter (CWA). The feed cable is connected to the Versatee.



The antenna is effectively a half wave dipole which means the feedpoint impedance is low, and this suits the transmitter well. It also means that the far end of the sloping wire (counterpoise) is a high impedance. Because of this the end is at a high voltage and should **not** be connected to ground. It is recommended that it is attached to a non conducting post which is about 2 ft in height. This is completely contrary to the use of radials with a vertical groundplane antenna.

The standard Versatee Vertical is configured as shown in the previous figure with a 22 inch antenna arm mounted to the top of the Versatee and a red coil mounted on top of the arm.

A fully extended standard whip is mounted to the top of the coil (not shown in illustration).

The counterpoise should be approximately one quarter wavelength so it should be adjusted for each band. Also the amount of inductance required to tune the upper portion changes for each band. Approximate settings for both of these are shown in the table below.

BAND	TAP POSITION (turns from whip end)	COUNTERPOISE LENGTH (Feet/Inches)
40m	38	31 ft
30m	18	28 ft
20m	13	13 ft 2in
17m	8	10 ft 6in
15m	5	10 ft
12m	3	7ft 6 in
10m	1	7ft 6 in

Like any of the Buddipole configurations there is room for experimentation. For example the coil can be mounted directly to the Versatee or a black coil could be used in place of the red coil. These alternatives will work too, but the coil settings will be different from those in the table above.

The figure to the right shows the typical setup for the Versatee Vertical using the 25 or 50 ft cable assembly connected directly to the Versatee terminals (whip left out to simplify the view).

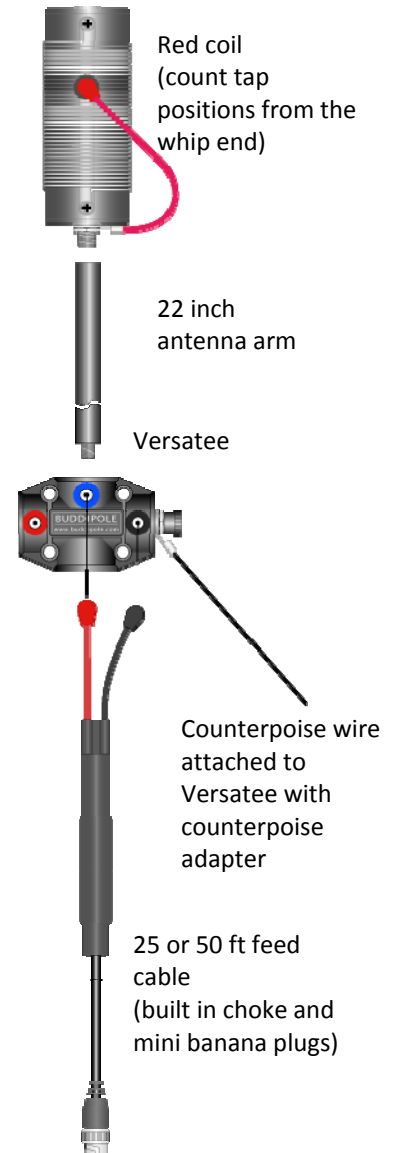

3.3 BUDDIPOLE 2 ELEMENT HORIZONTAL YAGI

The modularity of the Buddipole system provides the ability to build many different types of antennas.

By collecting a few more parts you can convert your Buddipole into a 2 element yagi (a 3 element version is also possible).

The driven element is a horizontal half wave dipole, and the reflector is a half wave parasitic element comprised of two telescopic whips and an IT adapter.

The boom is formed by two antenna arms connected by a second IT adapter to the mast. A yagi mast adapter (YMA) is required to adapt the mast to the IT connector with the older style masts, but is not needed with the new version of mast.

Yagi collars (also called IT collars) are used to clamp the elements to the boom to prevent the elements from swiveling out of horizontal alignment.

There is an accessory kit available for those who already own the Buddipole Deluxe package. The kit contains the following items:

ITEM	QUANTITY
IT adapter (ITA)	2
IT collar (ITC), also known as the Yagi collar	2
Yagi Mast adapter (YMA), not required with latest mast	1
Threaded stud	1
Standard 66 inch Telescopic whip (Deluxe kit contains 3 whips)	1

NOTE: Owners of the Buddipole package will need to add soft knobs. These are included with the Rotating Arm Kit (RAK).

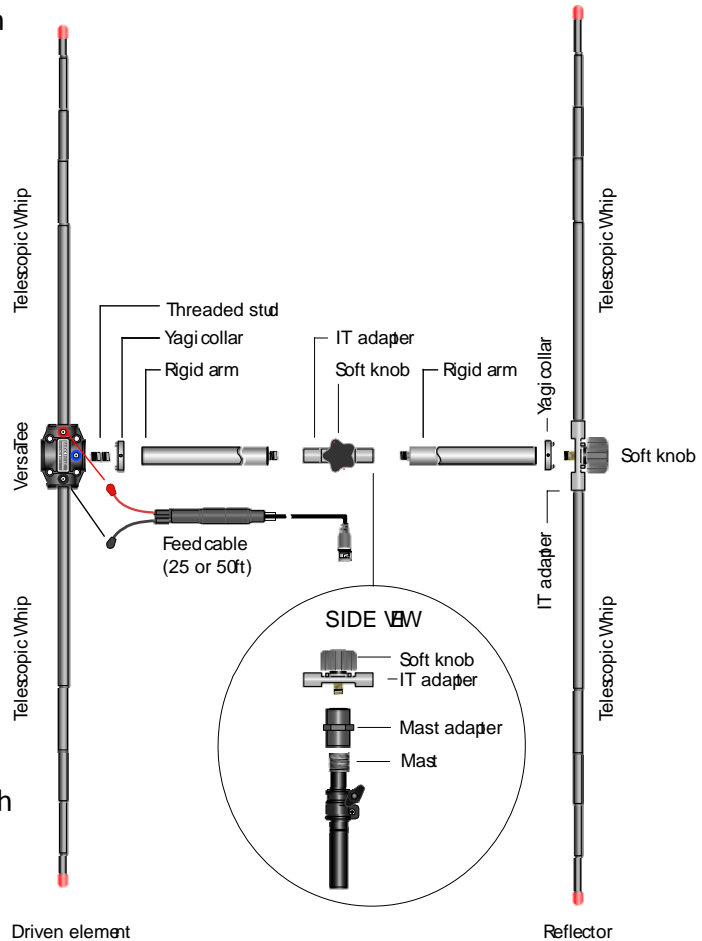

3.4 OTHER CONFIGURATIONS

The three previous examples are just a few of the many different antennas that can be made with the Buddipole family of products. Buddipole users have experimented with many different types of antennas ranging from vertical arrays to three element Yagis. This paper is intended to give you a view of the different Buddipole accessories that will allow you to go well beyond the basic dipole or vertical configuration. There is much more to follow ...

SUGGESTIONS? Please email us at info@buddipole.com.

Please see our instructional videos at www.youtube.com/buddipole



KI6AWR in an anechoic chamber. Simulates the outdoors but without the view!
One of the few places where you can really hear yourself think?