

# A Comprehensive Guide Book

FOR  
THE HAM RADIO ENTHUSIASTS

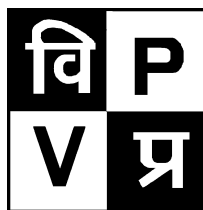

**Vigyan Prasar**

(An autonomous organization under the Department of  
Science & Technology),  
C-24, Qutab Institutional Area,  
New Delhi-110 016

E-mail: [vigyan@hub.nic.in](mailto:vigyan@hub.nic.in)

### FOREWORD

Considering the utility and potential of ham radio not only in emergency, but also as a means of triggering and promoting interest in science and technology, National Council for Science and Technology Communication (NCSTC) and Vigyan Prasar have been putting in efforts to popularize ham radio in India. This hobby has the potential to involve a vast majority of the young and energetic citizens of our country in a process of "Learning by Doing" in the field of electronics as well as wireless communication technology.

Vigyan Prasar is in the process of building up a nationwide science club movement under which a science club network has already been functioning (called the **Vigyan Prasar NETwork of Science Clubs-VIPNET**). These "**Science Clubs**" for the kids, if hooked through a network of ham radio stations, will enhance the interaction among the kids and other science enthusiasts. It will also provide an opportunity to the club members to do on-the-air voice communication without any cost. It may be recalled that ham radio operators played an important role during the Bharat Jan Vigyan Jatha (1987) in coordinating and monitoring the movements of Jatha, besides organising demonstrations of ham radio for the public. **Vigyan Prasar runs the amateur radio station VU2NCT which is located in the Technology Bhawan, New Delhi.** Few years back, Vigyan Prasar also developed a low cost 7 MHz QRP transceiver. **Vigyan Prasar runs a VHF Ham Repeater Station (VU2DLR) for the mobile operators in Delhi.**

It may be mentioned that **Dr. Narender K. Sehgal, Head of NCSTC & Director, Vigyan Prasar** himself is a ham radio operator (**Call-sign: VU3NKS**). He is also a winner of the highest International award ("Kalinga Award") in science popularization offered by UNESCO. **Dr. V.B. Kamble, Director, NCSTC, DST is the founder custodian of ham radio station VU2NCT.**

"*Catch them young*" is a phrase very popular with all educationists. The present education system provides ample scope for organizations like ours to contribute towards strengthening and supplementing the learning experiences of children by designing well focused programmes, especially in electronics, that encourage self-learning via electronic kits and toys; initiation into hobbies like amateur radio etc. Efforts in this direction are underway at Vigyan Prasar. This study material is compiled to help the ham radio enthusiasts in their preparation for the Amateur Station Operator's Certificate (ASOC) examination conducted by the Ministry of Communications for awarding of amateur radio operator's licence. Readers may also refer to the ham radio section of the Vigyan Prasar homepage (URL: [www.vigyanprasar.com](http://www.vigyanprasar.com)) for more information.

This study material is compiled by:

**Sandeep Baruah, VU2MUE (Ex-VU2MSY)**

**Scientific Officer, Vigyan Prasar.**

You can get him at: [vigyan@hub.nic.in](mailto:vigyan@hub.nic.in)

**ACKNOWLEDGEMENT**

While preparing the radio and electronics theory portion of the study material, various books were consulted and the some portions of the compiled material were heavily drawn from the following books:

1. Electronic Communication  
by Robert L. Shrader, W6BNB (McGraw Hill, Inc.)
2. Electricity and Electronics Today  
by W.J. Haynie, III, (EMC Corporation, USA)
3. Radio Technology  
by Ashok Saxena (Sudha Publications Private Ltd., New Delhi)
4. Electronics Made Simple  
by Henry Jacobowitz (Doubleday & Company, Inc. New York)
5. Guide to Amateur Radio in India  
by Saad Ali, VU2ST (Amateur Radio Society of India)
6. Basic Radio (Volume-I to VI)  
by Marvin Tepper (D.B. Tarapoorevala & Sons Ltd. Mumbai)
7. <http://www.scimedia.com>

**CONTENT**

**Part-I: Introduction to ham radio PAGE**

- . What is Ham Radio?1
- B. Why an Amateur Radio Operator is called a ham?2
- C. What is the minimum qualification to become a ham?3
- D. What is an amateur radio call-sign?3**

**Part-II: Amateur Radio Rules & Regulation**

- . Detailed procedures related to application for a ham radio licence. 4
- B. Different grades of licencing examinations and licences.5
- C. Question and answer section on amateur radio rules & regulations.6
- D. Radio telephony operating procedure.13

E. Radio telegraphy operating procedure.15

F. The Indian Wireless Telegraphs (Amateur Service) Rules, 1978.19

G. Syllabus of Amateur Station Operator's Certificate (ASOC) Examination. 42

### **Part-III: Radio Theory and Practice**

. Elementary theory of electricity & magnetism48

B. Thermionic emission & valves74

C. Elementary theory and construction of semiconductor devices78

D. Radio receivers81

E. Transmitter89

F. Radio propagation 95

G. Aerials100

**Part-IV:** Learning the International Morse Code. 105

**Part-V:** Safety measures in a ham radio shack. 111

## Part-I

### Introduction to ham radio

#### . What is Ham Radio?

Ham radio operators are a group of people **nurturing a special interest in wireless communication technology**. People from all the spheres of life are found among the ham radio operators. They operate their wireless transceivers (a combined unit of radio transmitter and receiver) during their pastime for the sheer joy, thrill and excitement involved in doing a worldwide radio communication. Unlike the broadcast radio stations (to whom we usually tune our radio receivers to listen to), ham radio is a two-way communication system. Ham radio operators can put their voice on-the-air to be listened into and at the same time replied back by their fellow radio operators around the world.

Despite the existence of other communication facilities, ham radio operators run their own wireless communication network with entirely personal effort out of the love for this medium of communication. **There are some hams who, build their own wireless transceivers (a combined unit of transmitter and receiver) and transmit their voice signals throughout the world to be replied back by their fellow hams.** These are the experiment oriented hams who try to achieve some sort of a perfection in developing electronic circuits for radio frequency work, **or at a lower level, they may like to assemble a piece of wireless equipment designed by their fellow experts, modify it in their own way to improve its performance till they are satisfied with its performance.** Hams located in the other parts of the world reply back exchanging information about the quality and strength of their radio signals.

They exchange personal as well as technical information, which are not related to business or commerce, politics and religion. Though a ham cannot use his radio station for any pecuniary gain, a creative mind can still find numerous utility of ham radio. It is a pursuit, which attracts people from all the spheres of life. There are hundred and thousands of people who are laymen so far as their knowledge of electronics is concerned, yet, they are

expert ham radio operators. **It is an exciting way to discover new friends and disseminate knowledge on-the-air. One interesting fact about ham radio communication is that hams don't have to pay any money to the authority for their on-the-air conversation**

With the availability of low cost **easily replicable circuits of radio transmitters and receivers, the number of ham radio operators increased to millions.** The growth of electronics communication technology is also considered to be going hand in hand with the progress of ham radio. The advancement in the field of electronics and **the flourishing growth of electronics industry in countries like Japan has been very often attributed to the presence of large group of dedicated ham radio operators (to the tune of 13,50,127).**

Though ham radio is a highly **specialized technical hobby**, it requires **no special qualification** (except that the person going to be a ham has attained 12 years of age). However, it demands immense interest in radio communication and sufficient enthusiasm to find reason to operate a radio station of your own, because **ham radio, also known as "Amateur Radio" does not provide you pecuniary gain.** What you gain from being a ham is more than what money can give and for that you got to be imaginative! Many of the foremost radio and electronics engineers and technicians operate as amateurs during times when they are not occupied professionally. Seeing the growth of ham radio population around the world, many professional companies started manufacturing ham radio equipment to meet the needs of the vast group of ham radio operators who prefer readymade professionally built equipment instead of homemade ones. So, what had once been a hobby for somebody, turned out to be a profitable profession. Hams never accept money for their on-the-air communication.

Young students can learn the principles of electronics through practical experimentation by assembling wireless transmitter and receiver kits in the ham radio clubs established in their schools. Without a valid ham licence, it is illegal to operate wireless equipment. In India, The **Central Board of Secondary Education (CBSE)** has also taken some initiative to include 'ham radio' in their course curriculum under the scheme of Work Experience. **The Member of Parliament Local Area Development Scheme** has also included 'Ham Radio' as one of its projects and as per the direction of the **Ministry of Programme Implementation, a Member of Parliament (MP) can spend money to establish ham radio stations in the schools located in his area.** If these schemes are fruitfully utilised, many youngsters would be able to take interest in ham radio which they may also make into career. **There are many activities people perform out of their scientific curiosity or to satisfy their inquisitive mind. Many people are attracted towards ham radio for this reason also.**

## B. Why an Amateur Radio Operator is called a ham?

The word "HAM" as applied to **1908** was the station CALL of the first amateur wireless station operated by some amateurs of the **Harvard Radio Club.** They were **ALBERT S. HYMAN, BOB ALMY** and **POOGIE MURRAY.** At first they called their station "**HYMAN-ALMY-MURRAY**". Tapping out such a long name in code soon became tiresome and called for a revision. They changed it to "**HY-AL-MY**", using the first two letters of each of their names. **Early in 1901** some confusion resulted between signal from amateur wireless station "**HY-ALMU**" and a Mexican ship named "**HYALMO**". **They then decided to use only the first letter of each name and the station CALL became "HAM".**

In the early pioneer days of unregulated radio, amateur operators picked their own frequency and call letters. **Then as now, some amateurs had better signals than commercial stations. The resulting interference came to the attention of US congressional committees in Washington and Congress gave much time to proposed legislation designed to critically limit amateur radio activity. In 1911, ALBERT HYMAN chose the controversial WIRELESS REGULATION BILL as the topic for the Thesis at Harvard. His instructor insisted that a copy be sent to Senator DAVID L. WALSH, a member of one of the committees hearing the Bill.** The Senator was so impressed with the Thesis that he asked HYMAN to appear before the committee. ALBERT HYMAN took the stand and described how the little station was built and almost cried when he told

the crowded committee room that if the BILL went through they would have to close down the station because they could not afford the license fee and all the other requirements which the BILL imposed on amateur stations. **Congressional debate began on the WIRELESS REGULATION BILL and little station "HAM" became the symbol for all the little amateur stations in the country crying to be saved from the menace and greed of the big commercial stations who didn't want them around.** The BILL finally got to the floor of Congress and every speaker talked about the "**....poor little station HAM.**" That's how it all started. **You can find the whole story in the US Congressional Record.** Nation-wide publicity associated the station "HAM" with other amateur radio operators. From that day to this, and probably until the end of time in radio; and amateur is a "HAM." (Source: Florida Skip Magazine-1959)

### C. What is the minimum qualification to become a ham?

**No educational qualification is specified** to become a ham. Anybody who has **attained 12 years of age** can become a ham radio operator after passing the **Amateur Station Operator's Certificate (ASOC) Examination** conducted by the **Ministry of Communications, Govt. of India.** You have to send a "**Birth Certificate**" or the "**High School Leaving Certificate**" (which mentions your date-of-birth) as a proof of your age.

**There are four different grades of Amateur Wireless Telegraph Station Licence.** Those between the **age group of 14-18 years** can apply for **Grade-I, Grade-II, Restricted Grade or a Short Wave Listener's licence** (listening to the ham radio operators without this licence is considered illegal). Those between the **age group of 12-14 years** can apply for **Grade-II, Restricted Grade or a Short Wave Listener's Licence.** The application for the grant of such licences should be accompanied by a certificate from the head of the educational institution recognized by a board or university in India, attended by the applicant or from his legal guardian that the applicant is interested in and is competent to conduct experiment in wireless communication.

### D. What is an amateur radio call-sign?

Each **amateur radio station (ham radio station)** has its own unique "**name**" allotted by the authorities. In amateur radio, **the unique name assigned to a ham radio station and its owner** helps you to know **its operator** as well as **the country** to which he belongs. This particular ham radio station is authorized to be operated by that particular ham radio operator only. However, other licensed ham radio operators are also eligible to operate his station provided they hold licences of the same category (**and not lower than the category which he holds**) and the owner of that particular station is physically present during the operation. **A person who does not hold a ham radio licence is not authorized to operate a ham radio station.** This also means that only a single station with a particular call-sign can exist in a particular location. A person having a ham radio call-sign is not authorized to set up more than one ham radio stations at different locations.

A call-sign consists of a set of letters and numbers, assigned by the authority. For example **VU2XYZ** is a call-sign which belongs to a particular ham in India. No other hams anywhere in the world can have this call-sign! Similarly, **4S7VK** is a call-sign which belongs to a ham from Sri Lanka. In a call-sign, the letters before the number is called the **prefix**. So, there might be a ham with the call-sign **4S7XYZ** in Sri Lanka. Similarly, a call-sign like **VU2VK** may exist in India! Each country has its own prefix. The knowledge of prefix helps us identifying the country of origin of a particular amateur radio transmission.

When a ham radio station is set up on board a ship, the call-sign should be followed the suffix **/MM**. So, **VU2XYZ** would become **VU2XYZ/MM (maritime mobile)** when it operates from a ship. If it operates from a vehicle, then the call-sign becomes **VU2XYZ/M (mobile)**.

## Part-II

### Amateur Radio Rules & Regulation

## A. Detailed procedures related to application for a ham radio licence

The ham radio licencing examination is known as the Amateur Station Operator's Certificate Examination (ASOC examination). It is conducted by the **Wireless Planning and Coordination (WPC) wing of the Ministry of Communications, New Delhi** at the **Wireless Monitoring Stations** located throughout the country. You should apply to the 'Officer-in-Charge' (OC) of the Monitoring Station nearest to your hometown. Basically the examination consists of a **100 marks question paper** (50 marks related to basic radio/electronics theory as per the syllabus and 50 marks related to Amateur Radio Rules & Regulations) which is of **one, two or three hours** duration as per the "Grade" of licence you will be going for. There are 4 Grades. You can apply for more than one grades at a time (or for only one grade), provided, separate application forms along with the prescribed examination fees separately for each grade in the form of **Demand Draft** issued from a "State Bank of India" branch drawn **in favour of the "Pay & Accounts Officer (Headquarters), Department of Telecommunications, New Delhi-110001, payable at SBI New Delhi Main Branch (Code No. 0691)** are sent to the "**Officer-in-Charge**" of the **Wireless Monitoring Station** (in no case application be forwarded to WPC Wing, New Delhi) where you will be appearing for the ASOC examination.

The particulars of the "Venue" and "Date" etc. of the examination will be communicated by the Officer-in-Charge of the concerned Wireless Monitoring Station on receipt of completed application form with the requisite examination fees

Following should accompany the application:

- (1) **Nationality Certificate**/Character Certificate in the prescribed proforma (find the proforma in "Indian Rules & Regulation" section of this book) from a gazetted officer.
- (2) **2 copies of recent passport size (3 x 4 cms) photographs** duly signed by you on the front side.
- (3) Examination fees in the form of **Bank Draft (DD) drawn from a SBI branch** of appropriate amount.
- (4) **Personal particulars** (4 copies) in the prescribed proforma (find the proforma in "Indian Rules & Regulation" section)
- (5) An **attested copy of birth certificate or School Leaving certificate** as a proof of your age (the minimum age requirement to appear for the examination is 12 years)

After the declaration of the result, a copy of the result and your "Personal particulars" will be forwarded by the Wireless Monitoring Station to the WPC Wing of the Ministry of Communications, New Delhi. The WPC Wing, New Delhi will then inform the concerned Department of the Ministry of Home Affairs for a 'Security Clearance'/Police Verification. After the police verification report is received with a clearance, the WPC Wing will write to you that you will be awarded a "Amateur Wireless Telegraph Station Licence" on payment of the requisite "Licence fee". Remember that '**Examination Fee**' and '**Licence fee**' are different and the '**Licence fee**' should be sent only when asked for. This time, the mode of payment is same as above, but you have to send it directly to the-

**Assistant Wireless Adviser to the Govt. of India,**  
**WPC Wing** of the Ministry of Communications,  
Amateur Radio Section,  
Dak Bhawan, Parliament Street,  
New Delhi-110 001

## B. Different grades of licencing examinations & licences

(1) **Restricted Grade Amateur Station Operator's Licence** (if you pass Restricted Grade ASOC Examination): Permits **line-of-sight short distance terrestrial communication** using a power output of **10 Watts** (dc input power) in the Very High Frequency (VHF) band. The frequencies allocated in this band ranges from **144 to 146 MHz**. Modes of communication allowed are: **Radio Telephony**(Voice) using **Amplitude Modulation (AM)**, **Single Side Band (SSB)**, SSB Suppressed Carrier, SSB reduced carrier and **Frequency Modulation (FM)**. **It is advisable not to go for this Grade of licence because communication is limited to a very short distance** (a typical possible range may be 35 km only depending on the height of the antenna or the type of terrain). **This type of licence is useful in a place where there are large number of ham radio operators.**

(2) **Grade II Licence** (if you pass Grade-II ASOC examination): Permits **worldwide long distance communication** in **AM, SSB, FM** using a power output of **50 watts** in different allotted **short wave bands (high frequency-HF bands)** including the **VHF band** mentioned above. **But entitlement for authorization of voice communication (radio telephony) is on the basis of providing proof of having made 100 contacts with other amateur radio stations using Morse Code (Called Continuous Wave-CW communication).** This means that you have to send back your original licence to the WPC wing for "**Voice endorsement**" along with the photocopies of your log book (see Rules & Regulation Section).

(3) **Grade-I:** (if you pass Grade-I ASOC examination): Power output is **150 watts** in short waves (in the allotted HF bands), **25 watts in VHF & UHF (Ultra High Frequency-for satellite communication)**. With this licence **you can directly use voice** including Morse Code. Other advanced modes like **Radio Tele-Typing (RTTY)**, **Amateur Radio Teleprinting Over Radio (AMTOR)**, **Packet Radio (-an advanced techniques of digital data communication through computer connected to a wireless transceiver)**, **Amateur Television (ATV** using Slow Scan Telecast: SSTV). You are also permitted to work amateur radio communication satellites with this licence.

(4) **Advanced Grade:** Same as Grade-I licence but allowed to use **400 watts** of power in selected sub-bands. **This is the highest grade licence in India.** Every ham radio enthusiast in India aspires to get it.

## Practical Test

There is a practical test on Morse Code sending and receiving (except for Restricted Grade Licence where this test is not required). This is a 10 minutes duration test to examine the candidates proficiency in sending and receiving Morse Code. To learn Morse code, a Morse Code Practice Oscillator can be assembled along with a Morse Key and a Morse Code learning Cassette can be found useful (See Morse Code learning Section of this book).

## C. Question and Answer Section on Amateur Radio Rules & Regulations

### Q. What do you mean by 'Amateur Radio Service'?

'Amateur Radio Service' is a two-way radio communication service allotted to persons who are licensed by the communication authority to carry out experimentation in the field of radio communication techniques. The Indian Wireless Telegraphs (Amateur Service) Rules 1978 defines 'Amateur Service' as -"*a service of self training, inter-communication and technical investigations carried on by amateurs that is, by persons duly authorised under these rules interested in radio technique solely with a personal aim and without pecuniary interest*".

### Q. What types of messages are forbidden to be transmitted from an amateur radio station?

A ham radio operator is allowed to transmit in plain language and his message shall be of a technical nature



related to tests, remarks of personal character which are not related to business affairs or transactions. He is forbidden to transmit:

- i. Messages like the reproduction of broadcast programmes or tape recordings or transmissions of entertainment value or music.
- ii. False or misleading calls, or signals, news, advertisements, communications of business, statements on topics of political or industrial controversy.
- iii. Superfluous signals or any matter which is indecent or of obscene character or of a seditious tendency or which is grossly offensive or such as is likely to arouse racial, religious, or communal animosity; and
- iv. Messages for pecuniary reward or any messages for, or on behalf of third parties.

### **Q. Is third party communication allowed in India in 'Amateur Radio Service'?**

Third party communication is not allowed in India, except in case of failure of normal telecommunication facilities during earthquake, flood, cyclones, widespread fires or during any other disasters. Under such circumstances, a ham radio operator can handle third party messages pertaining to disasters. Such message should originate from and addressed to a competent civil authority namely, (a) district magistrates or deputy commissioners or collectors of the district and (b) any other officer authorized by the authorities mentioned at (a) above.

### **Q. What is 'Secrecy of Correspondence'?**

If any message which the ham radio operator is not entitled to receive is, nevertheless received, the ham radio operator shall not make known or allow to be known its contents, its origin or destination, its existence or the fact of its receipt to any person (other than duly authorized officer of the central government or a competent legal tribunal) and shall not reproduce in writing, copy or make any use of such message or allow the same to be reproduced in writing, copied or made use of.

### **Q. What is a 'Ham Radio Net'?**

A ham radio net is a voluntary radio communication network formed under the initiative of a few hams which is maintained at scheduled time/times of the day (everyday or at scheduled days). The heart of the net is the 'net controller', who takes messages from the hams joining the net and pass it on to its respective destination. Different nets may have different objectives. For example 'Air NET India' is the National Emergency Traffic (NET) net run by the Amateur Radio Societies of India (ARSI). This net is conducted everyday from 7:00 PM to 7:30 PM (approximate ending time) on 14.150 MHz  $\pm$  QRM to handle any emergency medical traffic, other emergency traffic and to check the radio wave propagation condition. But one of the main objectives of this net is to provide the facility to the Indian hams to establish contact between two hams. A ham 'X' can pass on the request to the 'net controller' regarding his willingness to contact a ham 'Y'. The 'net controller' then helps both the station to make the contact in a mutually decided frequency. So every active hams should have the habit of checking this kind of net regularly.

### **Q. What is a distress call?**

A distress call is a call given from a ship, aircraft or vehicle indicating that the caller is threatened by grave and imminent danger, which requires immediate assistance. In **radiotelephony** transmission, the distress signal consists of the word **MAYDAY** (pronounced as the French expression '*m'aider*') spoken three times followed by the words THIS IS and the identification of the station seeking assistance. A distress message should be followed by the distress call.

It contains-name of the ship, aircraft or vehicle, position, type of distress and the type of assistance asked for including any other relevant information to facilitate rescue operation.

In **radiotelegraphy**, the distress signal consists of the letters **SOS** sent in Morse Code characters  $\dots\_ \_ \_ \dots$  (**SOS**). All these characters should be transmitted three times as a single signal where *dashes* are to be emphasized to enable distinguish them clearly from the *dots*. A typical distress message may look like: **S0S SOS SOS CQ CQ CQ DE** followed by the call-sign. When the distress traffic is over, the distress station should end its transmission with the Q-Code. It looks like: **SOS CQ CQ CQ DE 'call-sign' QUM SK**.

### Q. What action should you take if you receive a distress call?

The distress call has **absolute priority** over all other transmissions. Hence it would be my utmost duty to

- listen to the distress call and stop my transmissions if I was previously occupying that frequency;
- acknowledge receipt of the distress message if the station in distress can copy my signal.
- At the same time, it would be my duty to ensure that my transmission does not interfere with transmissions of other stations, which may be better situated to render assistance.
- Even if I cannot render assistance, I should direct the attention of other stations in the nearby frequencies, because they might be in a position to render immediate assistance.
- I shall also try to inform the appropriate authorities, who might be able to conduct a rescue operation.

### Q. What is an 'Urgency Signal'?

Urgency signal is a wireless message which indicates that the calling station has a vary urgent message to transmit concerning the safety of a ship/vehicle or that of a person but the message cannot be ranked as distress message. **Obviously, the urgency signal should be given priority over all other transmissions except distress call.**

In radio telephony, the word **PAN** is repeated three times pronouncing it as the French word '*panne*'. Other procedures to be followed in this type of traffic is same as that in distress traffic.

In radio telegraphy, the urgency signal consists of the group **XXX** ( $\_ \dots \_ \_ \dots \_ \_ \dots \_$ ) sent slowly three times. Letters of each group should be clearly separated from each other. The urgency signal transmitted by a ship can be addressed to a specific station. However, a coast station can transmit its urgency signal to all the ship stations after the approval of a responsible authority.

### Q. What is a 'Safety Signal'?

A safety signal is a message concerned with the safety of ships/vehicles indicating a meteorological warning (e.g. storm), danger to navigation warning or other navigational-aid message. Safety Signal is an important message because a delay in its transmission or reception can bring a disaster.

In radio telephony, safety signal consists of the word '**SECURITY**' pronounced as '*say-cure-ity*'.

In radio telegraphy, it consists of the three repetitions of the group **TTT** ( $\_ \_ \_$ ) sent slowly followed by the station call-sign. Letters of each successive group should be clearly separated from each other.

### Q. What is an amateur radio call-sign?

Each amateur radio station (ham radio station) has its own unique "name" allotted by the authorities. Just as the telephone number helps you to know its owner, in amateur radio, the unique name assigned to a ham radio station helps you to know its operator. This unique name is called the "Call sign". A call-sign consists of a set of letters and numbers, assigned by the authority. For example VU2RCH is a call-sign which belongs to a particular ham in India. No other hams anywhere in the world can have this call-sign! Similarly, 4S7VK is a call-sign which belongs to a ham from Sri Lanka. In a call-sign, the letters before the number is called the prefix. So, there might be a ham with the call-sign 4S7RCH in Sri Lanka. Similarly, a call-sign like VU2VK may exist

in India! Each country has its own prefix. The knowledge of prefix helps us identifying the country of origin of a particular amateur radio transmission.

### Q.What do you understand by the word 'phonetics' in amateur radio communication?

If we listen to a two-way amateur wireless conversation for the first time in our life, we would come across certain words, which perhaps we never heard before! There is every possibility that we mistake these words for some kind of secret codes! These words in fact are internationally used to do plain language (**conversation in secret code language is not allowed in amateur radio communication**) conversation and known as phonetics.

A ham radio operator has to face different types of hurdles during an ongoing communication. There may be static noise, signal fading, interference from other station operating at close frequencies, local noises in the radio room, unusual voice accents of the other operator, improper pronunciation of words. During these and many other difficulties, it has been found that use of phonetics improves the intelligibility in communication. For example, the letter '**D**' is represented by the word '**Delta**' in phonetics while the letter '**B**' is represented by '**Bravo**'. To distinguish '**M**' from '**N**', hams use the words '**Mike**' and '**Nancy**' respectively.

Phonetic alphabet is useful when calling distant station or when the band is crowded, or when for any reason the station called is expected to have difficulty in copying voice signals. For example, the word 'Solstice' can be spelt using phonetic alphabet as *Sierra Oscar Lima Sierra Tango India Charlie Echo*. A person conversant in listening to such phonetics gets habituated in spontaneously writing down the exact word out of these phonetics! He feels more comfortable at writing down a message spelt out in phonetics rather than simple mentioning of each letters.

Phonetics are to avoid confusion and not to create confusion! Many letters of the alphabet sound similar unless very clearly heard. B may be heard as G or D or V. The word 'bed' may be heard as 'bet' or 'pet'. So, if we spell it out with phonetics like **Bravo Echo Delta**, the confusion easily gets eliminated! Good operating procedures include using the standard phonetic alphabet to help communicate more clearly. The recommended phonetics are those also in use by aviation (internationally by ICAO treaty) and some militaries (in most English-speaking countries.) The numbers are spelled differently to suggest a particular pronunciation. Also, nine was changed to "niner" to avoid confusion with the German word "*nein*" for "no". When first making contact with another Ham, it is a good idea to say call signs in phonetics to give the other side a better chance of understanding them correctly.

### Phonetics used by amateur radio operators

<u>Letter</u>	<u>Word used as phonetics</u>	<u>Spoken as</u>
A	Alpha	AL FAH
B	Bravo	BRAH VOH
C	Charlie	CHAR LEE
D	Delta	DELL TAH
E	Echo	ECK OH
F	Foxtrot	FOKS TROT
G	Golf	GOLF

H	Hotel	HOH TELL
I	India	IN DEE AH
J	Juliet	JEW LEE ETT
K	Kilo	KEY LOH
L	Lima	LEE MAH
M	Mike	MIKE
N	November or Nancy	NO VEM BER
O	Oscar	OSS CAH
P	Papa	PAH PAH
Q	Quebec	KEH BECK
R	Romeo	ROW ME OH
S	Sierra	SEE AIR RAH
T	Tango	TAN GO
U	Uniform	YOU NEE FORM
V	Victor	VIK TAH
W	Whiskey	WISS KEY
X	X-ray	ECKS RAY
Y	Yankee	YANK KEY
Z	Zulu	ZOO LOO

### Phonetics used against figures or marks

<u>Figure or mark</u>	<u>Word used as phonetics</u>	<u>Spoken as</u>
0	NADAZERO	NAH-DAH-ZAY-ROH

1	UNAONE	OO-NAH-WUN
2	BASSOTWO	BESS-SOH-TOO
3	TERRATHREE	TAY-RAH-TREE
4	KARTEFOUR	KAY-TAY-FOWER
5	PANTAFIVE	PAN-TAH-FIVE
6	SOXISIX	SOK-SEE-SIX
<b><u>Figure or mark</u></b>	<b><u>Word used as phonetics</u></b>	<b><u>Spoken as</u></b>
7	SETTENSEVEN	SAY-TAY-SEVEN
8	OKTOEIGHT	OK-TOH-AIT
9	NOVENINE	N0-VAY-NINER
Decimal point	DECIMAL	DAY-SEE-MAL
Full stop	STOP	STOP

## Q. What are Q-codes?

A 'Q-code' consists of three letters starting with the letter 'Q'. Q-codes are devised to facilitate faster communication in Morse code. Instead of sending a long sentence, the amateur radio operator can just send a combination of three letters to represent a long sentence. If the amateur radio operator asks something to his fellow operator, then the Q-code is followed by a question mark. If the Q-code is used to represent a statement (not a question), then it is not ended with a question mark. For example, if you want to ask your friend on the air whether he is busy (Are you busy?), the Q-code will be 'QRL?'. If you want to say that you are busy, send 'QRL'. There are nearly 100 Q-Codes used by the marine radio operators. We have mentioned below the Q-codes required to be learnt by an amateur radio operator. Q-codes are very often used during the voice communication also.

QRA? What is the name of your station?

QRA The name of my station is .....

QRG? Will you tell me my exact frequency (or, that of .....)?

QRG Your exact frequency (or, that of ..... ) is ....kHz (or MHz).

QRH? Does my frequency vary?

QRH Your frequency varies.

QRI? How is the tone of my transmission?

QRI The tone of your transmission is: (1) Good. (2) Variable. (3) Bad.

QRK? What is the readability of my signals (or, those of....)?

QRK Readability is: (1) Unreadable. (2) Readable now and then. (3) Readable with difficulty. (4) Readable. (5) Perfectly readable.

QRL? Are you busy?

QRL I am busy (or, busy with .....). Please do not interfere.

QRM? Are you being interfered with?

QRM I am being interfered with.

QRN? Are you troubled by static noise?

QRN I am troubled by static noise.

QRQ? Shall I send faster?

QRQ Send faster (.... wpm)

QRS? Shall I send more slowly?

QRS Send more slowly.

QRT? Shall I stop sending?

QRT Stop sending

QRU? Have you anything for me?

QRU I have nothing for you.

QRV? Are you ready?

QRV I am ready.

QRW? Shall I inform ..... that you are calling him on .....kHz?

QRW Please inform ..... That I am calling him on ..... kHz.

QRX? When will you call me again?

QRX I will call you again at .....hours.

QRZ? Who is calling me?

QRZ You are being called by.

QSA? What is the strength of my signals (or those of .....)?

QSA Your signals are (1) Scarcely perceptible. (2) Weak. (3) Fairly good. (4) Good. (5) Very good.

QSB? Are my signals fading?

QSB Your signals are fading.

QSL? Can you acknowledge receipt?

QSL I am acknowledging receipt.

QSO? Can you communicate with ..... direct or by relay?

QSO I can communicate with .... Direct or by relay through .....

QSU? Shall I send or reply on this frequency (or, on ...kHz)(with emissions of class...)?

QSU Send or reply on this frequency (or, on .... KHz) (with emissions of class ....).

QSV? Shall I send a series of 'V's on this frequency (or, .... KHz).

QSV Send a series of 'V's on this frequency (or, .....kHz).

QSW? Will you send on this frequency (or, ... kHz)(with emissions of class ...)?

QSW I am going to send on this frequency (or, .....kHz) (with emissions of class ....).

QSX? Will you listen to ....(call-sign) on .....kHz?

QSX I am listening to ... (call-sign) on .....kHz.

QSY? Shall I change my transmission to another frequency?

QSY Change your transmission to another frequency.

QSZ? Shall I send each word or group more than once?

QSZ Send each word or group twice (or, ..... times).

QTC? How many telegrams have you to send?

QTC I have ..... telegrams for you (or, for .....).

QTH? What is your position in latitude and longitude (or, according to any other indication)

QTH My position is ...latitude .....longitude (or, according to any other indication).

QTR? What is the correct time?

QTR The correct time is .....hours.

QUM? Is the distress traffic ended?

QUM The distress traffic is ended.

### **Q. What are the designation of emissions allotted to amateur radio service?**

The most common designation of emissions, which are allotted to hams, are:

**A1A** : Continuous Wave (CW) Double side-band telegraphy for aural reception which contains quaternized digital information without the use of modulating subcarrier. (allotted to Grade II , Grade I and Advance Grade Licence holders)

**A2A**: Continuous Wave (CW) Double side-band telegraphy for aural reception, which contains quaternized digital information with the use of modulating subcarrier.

**A3E**: Double side-band single channel analog transmission containing telephony (including sound broadcasting). Commonly known as AM (Amplitude Modulation).

**H3E**: Single side band, full carrier single channel analog transmission containing telephony

(including sound broadcasting).

**J3E:** Single side band, suppressed carrier single channel analog transmission containing telephony (including sound broadcasting).

**R3E:** Single side band, reduced or variable-level carrier single channel analog transmission containing telephony (including sound broadcasting).

**F3E:** Frequency modulated single channel analog transmission containing telephony (including sound broadcasting).

**F1B:** Frequency modulated single channel telegraphy transmission containing quantized digital information for automatic reception.

**F2A:** Frequency modulated single channel telegraphy transmission containing quantized digital information for aural reception.

**F2B:** Frequency modulated single channel telegraphy transmission containing quantized digital information with modulating sub-carrier for automatic reception.

**F3C:** Frequency modulated single channel analog facsimile transmission.

**A3C:** Amplitude modulated double side-band single channel analog facsimile transmission.

**A3F:** Amplitude modulated double side-band single channel analog video transmission.

Each letter/digit of the designation of emission represent independent meaning as assigned to them.

## D. Radio Telephony Operating Procedure

Once you get your ham radio licence and the call-sign, it is time for you to start transmission. Radio waves are nowadays a precious commodity and so the ham should not misuse them for his own ends. It is the duty of the ham to know the correct operating procedure. If a newly licenced ham radio operator is ignorant about the correct operating procedures, he may create nuisance in the band. A ham should also be aware about the International Code devised by Paul M. Segal.

### Code for a ham radio operator

1. The ham is considerate. He/She never knowingly uses the air (radio waves) in such a way as to lessen the pleasure of others.
2. The ham is loyal. He/She offers his/her loyalty, encouragement and support to his/her fellow hams, his/her local clubs.
3. The ham is progressive. He/She keeps his/her station (radio equipment) abreast of science. It is well-built and efficient. His/Her operating practice is above reproach.
4. The ham is friendly. Slow and patient sending when requested, friendly advice and counsel to the beginner, kindly assistance, co-operation and consideration for the interests of other; these are the mark of the ham spirit.
5. The ham is balanced. Radio is his/her hobby. He/She never allows it to interfere with any of his/her duties he/she owes to his/her home, his/her job, his/her school or community-and lastly his/her knowledge and his/her radio station are always ready for the service of his/her country and his/her community.

### Calling another station

A call may be given to another station either in voice or using the Morse code. But before giving a call, it is the



duty of the ham to check whether the frequency he is going to use is already in use by other ham/s or not. Even though a particular frequency seems to be idle, it may not be so. Because, there may still be a ham sending his message whose signals are in skip with us (see questions & answers related to radio wave propagation) and another ham at a different location is listening to him. Giving a transmission in the same frequency in such a situation may interfere with the ongoing communication. So, prior to our transmission, it should be ascertained by sending the message-"Is the frequency in use?". This should be repeated two more times and if no reply has been received, then we can occupy the frequency. After occupying a frequency, we can give a **'General Call'** or a **'Directional Call'**. A **'General Call'** is a call given to all the stations. This means that you will reply to anybody from any part of the world. The message sounds like –"**CQ CQ CQ this is Victor Uniform Two.... (your call-sign suffix in phonetics) calling CQ on 20 metre and standing by**". The **'CQ'** message may be repeated for three time before giving the **'standing by'** message. As you **'stand by'**, listen carefully for any possible reply. If no reply is received, you can continue giving your CQ call. There is also a **'Directional Call'** which is **directed to a particular country or a particular station**. A call directed to a particular country is like-"**CQ Japan CQ Japan CQ Japan this is Victor Uniform Two .....**". This means that you will reply to stations from Japan only. A call may be directed to a particular station also. In this case, the country name is to be replaced with the intended station **'call-sign'**. **A person with the true ham spirit does not adhere strictly to his directional call, and as such should not deny reply to a ham from another country replying to his directional call (in the above example) until and unless he is in real emergency. Also there is nothing official about a ham radio operation.** Too much of formalities should be avoided as it may dishearten another fellow ham, also it is against the code devised by Paul M. Segal. Ham radio operators also form net. When a net is going on, you can also join the net once somebody in the net **'pulls you'** into the net. To indicate that you want to join the net, a short **'BREAK'** call may be given.

After establishing contact and offering the initial greetings, **a signal report** should be given to the other station. Your name (**Handle**) and location (**QTH**) should then be spelled out clearly in internationally accepted phonetics. If the other ham finds difficulty in copying your voice signal due to poor propagation condition or due to the difference in pronunciation, you should not loose patience and the message should be repeated if requested. You can also give the weather report (**WX report**) with mentioning of the temperature in degrees Centigrade. After this, discussion regarding the antenna system and equipment (called-"**Working condition**") begins. Before closing the conversation with a particular station, **73** message (meaning **'Best of Regards'**) should be conveyed to the ham and his family and indication should be given whether you are closing down (**going QRT**) your station, you are changing your frequency (**QSYing**) or you are still occupying the frequency. This will help other stations to follow you in case they want to make a contact with you. If the conversation takes long time, both the stations should mention their call-sign at least at ten minutes interval.

### Signal Report in Radio Telephony

When on-the-air contact between amateur radio stations is established, both the stations exchange signal reports. This gives the idea about how strongly the ham radio stations are receiving each other. For telephony (voice), Readability and Signal strength scale is devised.

#### Readability Scale

#### Signal Strength Scale

Q1	Hardly perceptible; unreadable	R1	Unintelligible; barely perceptible
Q2	Weak; readable now and then	R2	Weak signals; barely readable
Q3	Fairly good; readable but with difficulty	R3	Weak signals; but can be copied

Q4	Good; readable	R4	Fair signals
Q5	Very good; perfectly readable	R5	Fairly good signals
		R6	Good signals
		R7	Moderately strong signals
		R8	Strong signals
		R9	Extremely strong signals

A 59 (5 and 9) report is the best report in radiotelephony. You should be honest in giving a signal report. Don't give a good report just to please your friend! There may be some problem in the antenna system of your friend's station due to which you are receiving him poorly. Or there may be some problem in the audio quality of your friend's transmission. Under such a situation, giving a false report will just misguide your friend and your friend may not be able to detect/rectify the fault in his system.

## E. Radio Telegraphy Operating procedure

In radio telegraphy contact using Morse Code, the RST (Readability, Signal Strength and Tone) system of reporting is followed. This system was devised by W2BSR, New York. Throughout the world, Morse code is still used very affectionately by thousands of ham radio operators. They make conversation as fluently as they do in voice using Morse code. In fact Morse Code has many advantages over voice communication in certain situations as well just for the cheer joy involved in this art of communication which we have discussed in the chapter on Morse code learning. In Morse code also, either general CQ call or directional call can be given. The calling format is given in the next page.

### General call:

**CQ CQ CQ DE VU2XYZ VU2XYZ VU2XYZ AR PSE K**

### Directional Call:

**CQ/VU2ABC CQ/VU2ABC CQ/VU2ABC DE VU2XYZ VU2XYZ VU2XYZ AR KN**

In Morse code, long words are usually avoided and hence only the abbreviated form of the words are sent. There are certain Internationally accepted Morse Code abbreviations which you should remember and use during communication. '**AR**' is synonymous to saying '**over**' in voice (A voice message should be ended with the word 'over to .....'). '**K**' is the invitation to transmit which is synonymous to saying '**go ahead**' in voice communication. A message ended with **KN** indicates that the message was directed to a particular station only. During an ongoing communication also, the message should be ended with '**KN**' which provides the information to the other stations that communication was already in progress between two stations. Each sentence of the message should be separated by '**BT**'. Given below is a typical Morse code message.

**VU2XYZ DE VU2ABC BT TNX FER CALL BT UR RST RST IS 579 BT MY NAME IS .....ES QTH IS ..... BT OK? AR VU2XYZ DE VU2ABC KN**

When you finally close your conversation with a particular station, indication should be given, i.e. the message should be ended with 'VA' (meaning '**over and out with .....**'). A typical closing message may look like-..... **VU2ABC DE VU2XYZ VA**. This means that VU2XYZ is now free to communicate with other stations.

## THE RST SYSTEM

<u>Readability</u>	<u>Signal Strength</u>	<u>Tone</u>
1-Unreadable	1-Faint, signals barely	1-Extremely rough hissing note
2-Barely readable, occasional words distinguishable	2-Very weak signals	2-Very rough AC note, no trace of musicality
3-Readable with considerable difficulty	3-Weak signals	3-Rough. Low-pitched AC note, slightly musical
4-Readable with practically no difficulty	4-Fair signals	4-Rather rough AC note, moderately musical
5-Perfectly readable	5-Fairly good signals	5-Musically modulated note
	6-Good signals	6-Modulated note, slight trace of whistle
	7-Moderately strong signals	7-Near DC note, smooth ripple
	8-Strong signals	8-Good DC note, just trace of ripple
	9-Extremely strong signals	9-Purest DC note

### Abbreviations used in Radio Telegraphy (Morse Code)

**AA** Artificial antenna

**CQ** General Call

**ABT** About

**CONDX** Conditions

**AGN** Again

**CU** See you

**ANI** Any

**CUL See you later**

**ANT Antenna**

**DF Direction Finding**

**BC Broadcast**

**DX Long distance**

**FB Fine Business**

**ECO Electron Coupled Oscillator**

**BCL Broadcast band Listener**

**ERE/HR Here**

**BCNU Be seeing you**

**ES And**

**BK Break**

**FER For**

**CK Check**

**FR For**

**CANS Headphone**

**FONE Telephony (voice)**

**CKT Circuit**

**GA Go ahead/Good afternoon**

**CLG Calling**

**GE Good evening**

**CO Crystal Oscillator**

**GM Good morning**

**CPSE Counterpoise**

**GLD Glad**

**GND Ground**

**GUD Good**

**HI Laughter**

**HPE Hope**

**HR Here**

**HRD Heard**

**HV Have**

**KCS Kilocycles**

**LID Bad operator**

**MNI Many**

**MO Master Oscillator**

**MCS Megacycles**

**ND Nothing doing**

**NW Now**

**OB Old Boy (Young male operator:a novice)**

**OM Old Man (Male operator: not a novice)**

**OP Operator**

**PSE Please**

**PX Press**

**QRP Very low power**

**QSL Received**

**OK R All received correctly**

**RCVD Received**

**RCVR Receiver**

**RPRT Report**

**RPT Repeat the message**

**RX Receiver**

**SA Say**

**SED Said**

**SIGS Signals**

**SWL Short Wave Listener**

**TKS Thanks**

**TNX Thanks**

**TX Transmitter**

**U You**

**UR Your/ You are**

**VA End of work**

**VY Very**

**WX Weather**

**WID With**

**WKD Worked**

**WL Will**

**WUD Would**

**XMTR Transmitter**

**XTAL Crystal**

**XYL Wife**

**YF Wife**

**YL Young Lady (unmarried)**

**73 Best of regards**

**88 Love & Kisses**

**BAREFOOT- A transmitter running without an external linear RF amplifier.**

**HARMONIC- Daughter or Son of the ham radio operator (just as the harmonic frequency generated out of the fundamental frequency!)**

## F. The Indian Wireless Telegraphs (Amateur Service) Rules, 1978

**GOVERNMENT OF INDIA  
MINISTRY OF COMMUNICATIONS  
(WPC Wing)**

### **Notification**

**The Indian Wireless Telegraphs (Amateur Service) Rules, 1978**

**G.S.R No. 1499/78-** In exercise of the powers conferred by section 4 and section 7 of the Indian Telegraph Act, 1885 (13 of 1885), the Central Government hereby makes the following rules for the conduct of wireless telegraphs in the amateur service, established, maintained, and worked by persons licenced under the said Act.

## 1. Short title and commencement

(1) These rules may be called the Indian Wireless Telegraphs (Amateur Service) Rules, 1978.

(2) They shall come into force on the 1st January, 1979.

## 2. Definitions

In these rules, unless the context otherwise requires-

(a) 'Act' means the **Indian Telegraph Act, 1885** (13 of 1885);

(b) '**Amateur service**' means a service of self training, inter-communication and technical investigations carried on by amateurs that is, by persons duly authorized under these rules interested in radio technique solely with a personal aim and without pecuniary interest; 'amateur station', and 'station' shall have the meaning respectively assigned to them in the Convention;

(c) '**Convention**' means the **International Telecommunication Convention, Malaga-Torremolinos, 1973**, for the time being in force and the Radio Regulations and the Additional / Radio Regulations annexed thereto but does not include any portion of the said Convention or Regulations regarding which the Central Government makes any reservation;

(d) 'Licence' means a licence granted under section 4 of the Act for an amateur wireless telegraph station.

## 3. Necessity for licence

No persons shall establish, maintain and work an amateur wireless telegraph station, except under and in accordance with the terms and conditions of an appropriate licence under these rules.

## 4. Categories of licence

There shall be five categories of licences, namely :

(i) Advanced Amateur Wireless telegraph Station Licence

(ii) Amateur Wireless Telegraph Station Licence, Grade - I

(iii) Amateur Wireless Telegraph Station Licence, Grade - II

(iv) Restricted Amateur Wireless Telegraph Station Licence

(v) Short Wave Listener's Amateur Wireless Telegraph Station Licence.

## 5. Eligibility for Licence

(1) A licence may be granted subject to such conditions contained in Annexure I to these rules

(i) to a person-

(a) who is a **citizen of India**;

(b) who is **not less than 18 years of age**;

(c) who qualifies the Amateur Station Operator's Examination for the award of licence or holds either of the following certificate of proficiency, namely:

(i) Radio-communication Operators' General Certificates;

(ii) First or Second Class Telegraph Operators' Certificates:

Provided that the holder of a Special Radio Telegraph Operator's Certificate may also be considered eligible for the award of Amateur Wireless Telegraph Station Licence Grade II.

(iii) To a bonafide amateur radio society, club, a school, college, institute or university in India, which has the aim of participating in the 'amateur service': Provided that the licence shall be issued in the name of an authorized official of the society, club, school, college, institute or university in India, holding a category of licence appropriate to the transmission to be conducted by the station, including amateur radio beacon transmissions.

(2) Notwithstanding anything contained in sub-clause (b) of clause (i) of sub-rule (1), the central government may grant, to bonafide experimenters between the ages of 14 and 18 years, Amateur Wireless telegraph Station Licence, Grade I and to those between the ages of 12 and 18, Amateur Wireless Telegraph Station Licence, Grade II or Restricted Amateur Wireless Telegraph Station Licence or Short Wave Listeners' Amateur Wireless Telegraph Station Licence: Provided that the application for the grant of such licences shall be accompanied by a certificate from the head of the educational institution, recognized by a board or university in India, attended by the applicant or from his legal guardian that the applicant is interested in and competent to conduct experiment in wireless telegraphy.

(3) Notwithstanding anything contained in sub-clause (c) of clause (i) of sub-rule (1), the Central Government may recognize, subject to any conditions it may prescribe from time to time, such other Radiotelegraph Operators' Certificates or Amateur Station Operators' Certificate as are issued by a competent authority in India or any other country as equivalent to qualifications referred to in aforesaid sub-rule, for the purpose of grant of a licence under those rules.

## **6. Application for licence**

(a) an individual, or

(b) an amateur radio society or club or a school, college or an institute or an university in India

-shall be made to the central government in Annexure II or Annexure III respectively to these rules, together with all the subsidiary forms and documents duly filled in and completed in all respects.

## **7. Eligibility for admission to Amateur Station Operator's Examination**

No person shall be eligible for admission to an examination for the grant of licence unless-

(a) such a person fulfils the provisions contained in sub-clause (a) of clause (i) of sub-rule (1) and either sub-clause (b) of clause (i) of sub-rule (i) or sub-rule (2) of rule 5;

(b) such person pays the fees on the following scale, namely:

(i) Advanced Amateur Station Operator's Examination Rs. 25.00

(ii) Amateur Station Operator's Grade I Examination Rs. 20.00



(ii) Amateur Station Operator's Grade II Examination and  
Restricted Wireless Telegraph Station Examination Rs. 10.00

(c) a period of at least one month has elapsed since he last appeared in an examination and failed.

## 8. Examinations

(1) The examinations for the grant of a licence shall be held at a place and on a date as may be notified by the Central Government from time to time.

(2) An application for licence in Annexure II to the rules shall be submitted not later than the 15th of the month preceding that in which it is desired to take the examination.

(3) Any person admitted to the examination and found guilty of impersonation or of submitting fabricated documents or documents which have been tampered with or of making statements which are incorrect or false or of suppressing material information or of using or attempting to use unfair means in the examination hall or otherwise resorting to any other irregular or improper means for obtaining admission to the examination may, in addition to rendering himself liable to criminal prosecution, be debarred either permanently or for a specified period from appearing in any of the examinations held for the award of licence under these rules:

Provided that no order under this sub-rule shall be made unless the person concerned has been given a reasonable opportunity for making a representation against the action proposed to be taken.

(4) If any person is found guilty of any malpractice referred to in sub-rule (3) after the grant of a licence to such person, the central government may, in addition to prosecuting him cancel the licence so given:

Provided that the central government may, pending the cancellation of the licence, suspend or endorse such licence:

Provided further that no order under this sub-rule shall be made unless the person concerned has been given a reasonable opportunity for making a representation against the action proposed to be taken.

## 9. Grant of Licence

Every category of licence shall be in the form set out in Annexure III to these rules.

## 10. Observance of conditions of licence, Convention and rules under the Act

(1) Every licenced amateur wireless telegraph station shall be established, maintained and worked in accordance with:

(a) the conditions contained in Annexure I to these rules;

(b) the provisions of the convention;

(c) the rules made by the central government under section 7 of the Act for the conduct of wireless telegraphs in so far as they are applicable.

(2) Notwithstanding sub-rule (1) the central Government may modify, vary, cancel or revoke any of the conditions of licence contained in the said Annexure I at any time either by specific notice in writing to the licensee, or by means of a general notice published in the Official Gazette or in a newspaper published in New Delhi.

(3) The licensee shall at his own expense, give effect to any variations in the conditions of licence,

## 11. Period of validity

A licence granted under these rules shall be issued for a period of 2 years or 5 years, as the case may be, commencing on the date of issue of the licence and expiring on the last day of the month preceding the month of issue.

## 12. Fee for licence

(1) A licence fee on the following scale shall be paid to the central government on receipt of instructions from that Government and in the manner directed by it -

---

Category of licence	Fee for 2 years	Fee for 5 years
---------------------	-----------------	-----------------

---

(i) Advanced Amateur Wireless Telegraph Station Licence Rs.50/- Rs.125/-

Licence

(ii) Amateur Wireless Telegraph Station Licence, Grade I Rs.40/- Rs.100/-

Grade I

(iii) Amateur Wireless Telegraph Station Licence, Grade II; Restricted Amateur Wireless Rs.25/- Rs.60/-

Telegraph Station Licence; Short wave

Listeners Amateur Wireless Telegraph Station

Licence.

---

The licence fee shall not be refundable on ground of licensee's inability to establish or make use of the licensed amateur wireless telegraph station or for adjustments towards higher category of licence.

(2) No holder of a licence shall be entitled to a refund of fees paid therefore on the ground of his inability to establish or make use of the licensed amateur station.

## 13. Authorized frequency bands, power and emission

A holder of licence shall use, as appropriate to the licence, such frequency bands, power and classes of emission as are set out in Annexure V of these rules:

Provided that the central government may by special or general order make changes in the usage of frequency bands, power and types of emission where that Government is satisfied, that it is expedient to do so keeping in view, among others, the provisions of the convention need for enforcement of better technical standards in respect of equipment and national and international radio interference pattern.

## 14. Renewal of licence

(1) On the expiry of the validity of a licence, it may be renewed for a period of two or five years, as the

case may be, if the licensee-

(a) makes an application for renewal, not earlier than 2 months but before the date of expiry;

(b) has actively operated an amateur wireless telegraph station during the validity of his licence and provides a certificate to the effect that he has made contacts with other amateur stations on at least 40 occasions per year, and in case of short wave listener, has intercepted amateur station on at least 40 occasions per year;

(c) Pays, a fee on the following scale, namely:

---

Category of licence	Fee for 2 years	Fee for 5 years
---------------------	-----------------	-----------------

---

(i) Advanced Amateur Wireless Telegraph Station Rs.50/- Rs.125/-

Licence

(ii) Amateur Wireless Telegraph Station Licence, Rs.40/- Rs.100/-

Grade I

(iii) Amateur Wireless Telegraph Station Licence, Rs.25/- Rs.60/-

Grade II; Restricted Amateur Wireless

Telegraph Station Licence; Short wave

Listeners Amateur Wireless Telegraph Station

Licence.

---

(2) The licence fee shall not be refundable on ground of licensee's inability to establish or make use of the licensed amateur wireless telegraph station or for adjustments towards higher category of licence.

(3) The document showing the renewal of licence issued by the central government shall be kept along with the licence to which it refers.

(4) It shall not be obligatory for the central government to issue a notice that the licence is due for renewal.

## 15. Surcharge for late renewal

In case the holder of licence does not apply for its renewal prior to the date of expiry of the licence referred to in sub-rule (1) of rule 14, he may apply for the renewal of licence subsequently also but within a period of two years after the date of expiry of the licence on payment of a surcharge at the rate of Rs. 10/- for every half year or part thereof. The licence in such a case, shall be renewed from the date of expiry of licence.

## 16. Register for wireless telegraphy apparatus

Every licensee shall maintain a register in respect of all wireless telegraphy apparatus established, maintained and worked by him at the amateur station in the form set out in Annexure VI of these rules.

## 17. Location of Amateur Station

The location of the amateur station shall be specified in the licence along with the usual residence of the licensee endorsed therein and it shall be operated only from the place so fixed.

Provided that the central government may permit the change of location if the licensee applies for it in writing giving particulars of the change and submits the licence for endorsement, and pays a fee of rupees five.

## 18. Portable and mobile amateur station

The central government may in addition to an amateur station licensed for a specified location issue a special authorization to establish, maintain and work an amateur station as a mobile station installed on board a motor vehicle or as a portable station or for the purpose of exhibiting the operation of amateur station at jamborees or for specific technical investigations in radio if -

(i) Application for such authorization is made at least 10 weeks in advance indicating, amongst other, the period for which the authorization is required, area of operation and the purpose;

(ii) The applicant holds an Advanced Amateur Wireless Telegraph Station Licence or an Amateur Wireless Telegraph Station Licence Grade I;

(iii) The applicant pays an additional fee of Rs. 10.

(2) The special authorization shall, in addition to the conditions specified in rule 10, be subject to conditions, namely:

(i) The special authorization shall not be issued for a period more than 90 days and may be extended for a further period of 90 days on request and on payment of fee of Rs.10/-;

(ii) The licensee's amateur station at the fixed location and the mobile station shall not communicate with each other;

(iii) The suffix 'MO' shall be added to the call-sign already authorized to the licensee, such call-sign shall be followed by the location of the station;

(iv) such other conditions as the central government may determine from time to time.

(3) The special authorization may be withdrawn or the conditions contained therein varied at any time by the central government.

## 19. Amateur Station on board ship

(1) Without prejudice to rule 17, the central government may on receipt of an application authorize establishment, maintenance and working of an amateur station on board a ship registered in India. Applications for such authorization shall be accompanied by a written approval of the master or owner of the ship concerned.

(2) The establishment, maintenance and working of amateur station on board ships shall, in addition to the conditions specified under rule 10, be subject to such other conditions as the central government may determine from time to time and such conditions, among others, shall include the following, namely:

(i) The amateur station on board ship shall be operated only while the ship is in international waters or Indian territorial waters. Its operation within the territorial waters of another country shall be in conformity

with laws and regulations of the country concerned.

(ii) It shall not be operated whilst the ship is in any harbour in India;

(iii) The call-sign allotted to such stations shall have suffix 'MS' followed by the call-sign of the ships in case of radiotelegraphy official name of the ship in case of radiotelephony.

(iv) The amateur station on board a ship shall be independent of ship radio communication, radio navigation and other safety services radio equipment and shall be operated in such a manner as not to cause harmful interference to these services of the ship. The amateur station shall have source of electrical energy independent of the ship station and shall also be electrically independent of it.

(v) The amateur station on board a ship shall discontinue operation at any time on request of an officer of the central government, the master or radio officer of the ship or any land station.

## **20. Loss and Issue of Duplicate of Licence and Document showing the Renewal of Licence**

(1) A person whose Licence or the document showing the renewal of licence has been lost, mutilated or destroyed shall notify the same to the central government. An application in Annexure VII of these rules for the duplicate shall be made to the central government embodying a statement of the circumstances involved in the loss, mutilation or destruction of the licence or the document showing the renewal of licence for which a duplicate is required. If the licence or the document showing the renewal of licence has been lost, the applicant must state the circumstances in which it was lost and that reasonable search has been made for it, and further that in the event it be found, either the original or the duplicate shall be returned for cancellation. The mutilated licence or the document showing the renewal of licence for which the duplicate is required should be forwarded along with the application for cancellation.

(2) The central government may issue duplicate copy of any licence or the document showing the renewal of the licence and the following charges shall be levied for such issue:

(i) For duplicate of licence - Rs. 10

(ii) For duplicate of the document showing the renewal of licence- Rs. 5

## **21. Revocation of licence**

(1) The central government may, at any time, revoke the licence-

(i) On the breach of any of the conditions of licence contained in

Annexure I; or

(ii) In default of payment of any fees payable under these rules;

Provided that, before revoking a licence, the licensee shall be given a reasonable opportunity of making a representation against the action proposed to be taken.

(2) The licensee shall not be entitled to any compensation arising out of revocation of his licence nor will any part of the fees paid for the licence shall be refunded for the period a licence stands revoked.

## **22. Transfer of licence**

A licence shall not be transferable:

Provided that the central government may permit the transfer of a licence granted to an authorized official of an amateur radio society or club or a school, college or an institute or an university in India in favour of his successor if such successor holds a category of licence appropriate to the transmissions to be conducted by the amateur station.

### **23. Operation of licenced amateur station**

No person other than the licensee shall be permitted to operate the licensed amateur station:

Provided that -

(a) In the presence of the licensee himself, the station may be operated by another person holding a valid licence of comparable or higher category. The licensee, however, shall be personally responsible for the observance of these rules as if he operates the station.

(b) In case of a licence issued to an authorized official of an amateur radio society, club, school, college, institute or university in India, the station may be operated by-

(i) a person who holds a licence equivalent or of higher category;

(ii) a person who holds a lower category of licence, where he operates the station on the frequency bands, emissions and power allocated to his category. In each of the cases aforesaid the licensee shall be responsible for the observance of this rule.

### **24. Surrender of licence**

A licence which is revoked or which has become invalid and licensee does not desire to renew it shall be surrendered to the central government for cancellation and record.

### **25. Dual holding of licence**

No person shall be granted more than one licence at the same time: Provided that the central government may exempt a person, holding a licence in his name for amateur radio society or a school, college or an institute or an university in India, from the operation of this rule.

### **26. Admission of foreign nationals in examination and grant of licence**

(1) Notwithstanding anything contained in these rules the central government may, subject to such terms and conditions as it may impose from time to time, admit a person, who is not a citizen of India, to an examination for the grant of a licence or grant him a licence if otherwise qualified.

(2) The conditions under sub-section (1) shall, among others, include the following, namely:

(i) The country of which the applicant is citizen, grants reciprocal facilities to Indian nationals:

Provided that it shall not apply where the central government considers that reciprocal facilities are not necessary;

(ii) The applicant is above the age of 18 years.

(iii) The applicant is holder of an appropriate category of amateur station operator's certificate or licence issued by a competent authority in any other country and recognised by the central government.

(iv) The licence under this rule shall be initially granted for a period of one year or for the period of validity of visa, for which the applicant's passport is endorsed, whichever is less, on payment of a proportionate licence fee as prescribed in Rule 12 subject to a minimum of fees payable of one year.

## **27. Penalty for breach of these rules**

Any breach of these rules, other than a breach, which is an offence under section 20 or 21 of the Act, shall be punishable with fine, which may extend-

- (i) When the person is licenced under the Act, to Rs.1000 and in the case of continuing breach a further fine of Rs.200 for every day after the first during the whole or any part of which the breach continues;
- (ii) When a servant of the person so licenced or another person is punishable for the breach one fourth of the amounts specified in clause (i).

## **28. Repeal and saving**

(1) On the commencement of these rules, the Indian Wireless Telegraphy (Amateur Service) Rules 1958, shall cease to be in force,

(2) Notwithstanding such cesser-

(a) Where before such commencement any person had passed the Amateur Station Operators Certificate Grade I or Grade II Examination, such person shall not be required to pass any such examination under these rules;

(b) Where, before such commencement any person was granted Amateur Wireless Telegraph Station Licence Grade-I, or any such Licence was renewed and the period for which such Licence was granted or renewed extends beyond the commencement of these rules, then, such Licence shall continue to be in force for the period specified in the licence.

## **Annexure I**

### **CONDITIONS**

### **FOR**

### **THE CONDUCT OF**

### **AMATEUR WIRELESS TELEGRAPH STATION**

[See rules 5 & 10]

## **1. Use of the Amateur Station**

(1) The amateur station shall be used as part of self-training, intercommunication and technical investigations in radio techniques solely with a personal aim and without pecuniary interest:

Provided that when the station is licensed to an amateur radio society or club, or a school, college or an institute or a University, the use of the station shall be confined to technical investigations and training in radio communication techniques without pecuniary interest.

(2) The station may also be used for the purpose of receiving transmissions in the standard frequency service to facilitate operation of the station within the authorized frequency bands.

(3) Except as provided in these rules, the licensee shall not assign, under-let or otherwise dispose of or admit any person to participate in the benefits of the licence.

## **II. Messages**

(1) (a) Radio communications may be exchanged with other stations similarly authorized. The amateur stations are forbidden to communicate with amateur stations of countries whose administrations have notified the International Telecommunication Union of their objection to such radio communication.

(b) Transmissions shall be made in plain language and limited to messages of a technical nature relating to tests and to remarks of personal character (excluding business affairs or transactions) in which the licensee, or the person with whom he is in communication, are directly concerned and for which, by reason of their unimportance, recourse to the public telecommunication service is not justified.

(c) Special recordings for reproducing sinusoidal tone or tones within the audio frequency spectrum that may be either constant or steadily changing in frequency may be used.

(2) The licensee is forbidden to transmit-

(a) Messages like the reproduction of broadcast programmes or tape recordings or transmissions of entertainment value or music;

(b) False or misleading calls, or signals, news, advertisements, communications of business, statements on topics of political or industrial controversy;

(c) Superfluous signals or any matter which is indecent or of obscene character or of a seditious tendency or which is grossly offensive or such as is likely to arouse racial, religious, or communal animosity; and

(d) Messages for pecuniary reward or any messages for, or on behalf of third parties;

(3) Notwithstanding clause (a), sub-condition (1) and clause (d), sub-condition (2) the licensees in case of failure of normal telecommunication facilities, are permitted to handle third party messages, pertaining to natural calamities such as earthquake, flood, cyclones and wide spread fires, originating from and addressed to a competent civil authority namely, (a) district magistrates or deputy commissioners or collectors of the district and (b) any other officer authorized by authorities mentioned at (a) above. The licensee shall inform by letter addressed to the licensing authority regarding the use of his amateur station for such purposes on each such occasion.

### **III. Frequencies, Emission and Power**

The amateur station shall be operated on frequencies that are within the frequency bands authorized to respective categories of licences under rule 13 and on such classes of emissions and power not exceeding that specified in the said rule.

### **IV. Frequency control and measurement**

(1) The transmitting apparatus shall be tuned as accurately as possible to ensure that no energy is radiated on any frequency outside the limits of the authorized frequency bands.

(2) The licensee shall have at the licensed amateur station a reliable frequency measuring equipment to verify, each time the frequency of the transmitter is changed and whenever it is necessary to check the transmitted frequency that emissions are within the authorized frequency bands. The licensee shall take all steps necessary to maintain the accuracy of the frequency measuring equipment.

### **V. Non-Interference**

(1) The amateur station shall be so designed, constructed, erected, maintained and worked as not to cause interference with any wireless telegraph service functioning, within or without India, in accordance with the provisions of the convention or the wireless signaling between any fixed, land or mobile stations of



Indian land, naval or air force or between such stations and any station abroad:

Provided that in the event of interference being caused by the station the licensee shall discontinue or restrict transmissions, pending adjustment of the equipment, on request from-

- (a) The Central Government; or
- (b) Any land station.
  - (2) The licensee shall deploy all necessary means to ensure that the radiated frequency is free from harmonics, key clicks, hum and other forms of spurious emissions.
- (3) The licensee shall ensure that the transmitter is not over modulated.
- (4) The use of class B emissions (damped waves) is forbidden.

## **VI. Log (Diary of the radio service)**

(1) A chronological record of all transmissions emanating from or received at the amateur station shall be kept in bound book (not loose leaf) showing the following:

- (a) Date and time of each transmission;
  - (b) A summary of the communications exchanged;
  - (c) A brief description of the experiments and tests undertaken;
    - (d) The call-sign of station or stations with which messages have been exchanged, times of establishing and terminating communication with each station and the frequency and type of emission employed in each case:
  - (e) Time of opening and closing down the amateur station;
  - (f) In case of portable or mobile amateur station the particulars of temporary location.
- (2) All times in the log shall be stated in the Indian Standard Time.
- (3) No gaps shall be left between entries in the log and they shall be made and initialed at the time of receiving and transmitting.
  - (4) In case the station is operated by a person other than the licensee (see rule 23), the licensee shall ensure that log is signed by that person indicating his name, call-sign and licence number.
  - (5) Licensee shall preserve the log for a period of one year from the date of last entry therein before it is destroyed:

Provided that no log shall be destroyed for such further period as the Central Government may direct.

- (6) The form of log is shown in the Table attached to these conditions.

## **VII. Wireless Telegraphy Apparatus**

- (1) The amateur station shall be equipped for reception as well as transmission except in the case of Short Wave Listeners Amateur Wireless Telegraph Station Licence when it shall be equipped for the former only.
- (2) The wireless telegraphy apparatus and other accessory equipment used or intended to be used by the licensee shall be so arranged as not to endanger the safety of licensee or other persons.

- (3) The wireless telegraph apparatus shall be kept in a safe condition and housed in such manner as to preclude access to unauthorized persons.
- (4) The transmitter shall be of a type that has frequency stability comparable to that of a crystal control.
- (5) Meters of standard accuracy shall be installed to measure the D.C. power input to the anode circuit of the final radio frequency stage of the transmitter.
- (6) The aerial used or intended to be used shall be so erected, fixed, or placed as not to cross above or fall on to any power, telegraph or telephone line. If required, the licensee shall take necessary steps to guard, to the satisfaction of the owner or owners concerned, so as to prevent any damage being done in the event of a break occurring in the aerial. The aerial installation shall not cause hazard to flight of aircraft and their heights shall be within the limits specified by the Director General of Civil Aviation in India from time to time. The licensee shall, if so directed, install and maintain beacon lights on and paint the mast of the station at his own cost.

### **VIII. Secrecy of Correspondence**

If any message which the licensee is not entitled to receive is, nevertheless received, the licensee shall not make known or allow to be made known its contents, its origin or destination, its existence or the fact of its receipt to any person (Other than duly authorized officer of the Central Government or a competent of legal tribunal) and shall not reproduce in writing, copy or make any use of such message or allow the same to be reproduced in writing, copied or made use of.

### **IX. (1) General Radiotelegraph and Radiotelephone Procedure**

- (a) Before transmitting, the station shall take precautions to ensure that its emissions will not interfere with transmissions already in progress. If such interference is likely the transmission shall not commence till there is an appropriate break in the communications in progress.
- (b) The call sign endorsed in the licence shall be sent for identification at the beginning and at the end of each period of transmission. When the period of transmission exceeds 10 minutes the call sign shall be repeated. Licensee shall not make transmission without identification or with false identification.
- (c) Prolonged calls and transmissions shall be avoided.
- (d) When it is necessary to spell out call sign, certain expressions, difficult words, abbreviations, figures etc., the phonetic alphabet and figure code given in the Convention shall be used.

### **(2) Call and Reply Procedure**

- (a) The call shall consist of The call sign of the station called not more than three times; The word DE (in case of radiotelegraphy) and the words 'This is' (in case of radiotelephony) and the call sign of the calling station, not more than three times.
- (b) The reply to call shall consist of the call sign of the calling station, not more than three times; The word DE (in case of a radiotelegraphy) and the words 'This is' (in case of radiotelephony) the call sign of the station called, not more than three times.
- (c) The call may be sent three times at intervals of two minutes; thereafter it shall not be repeated until an interval of 10 minutes during which the operator shall list in the frequency band in which the call has been made.
- (d) In case of general call to all stations the signal 'CQ' (in case of radiotelegraphy) and the words 'Hello

all stations' or the signal 'CQ' (in case of radiotelephony) shall replace the call sign of the station called in the calling procedure.

### **(3) End of Transmission and Work**

(a) Transmissions of a message shall be terminated by the signal AR (in case of radio, telegraphy) and by the word 'Over' (in case of radiotelephony).

(b) The end of work between two stations shall be indicated by each of them by means of the signal VA (in case of radiotelegraph) and by the word 'OUT' (or VA spoken as Victor Alfa) in case of radiotelephony.

### **(4) Tests:**

(a) When it is necessary to make test signals either for the adjustment of a transmitter or a receiver or for any experiment, such signals shall not be continued for more than 3 seconds and shall be composed of series of VVV followed by the call-sign of the station emitting the test signals. In case of radiotelephony series of VVV shall be replaced by the figures 1,2,3,4... spoken in the figure code.

(b) For tests exceeding 30 seconds an artificial aerial shall be used.

(c) Emission of carrier wave is forbidden unless such wave is subjected to intelligible modulation.

## **X. Inspection**

(1) Any officer authorized by the Central Government in that behalf in writing by them, may at all reasonable times enter the station solely or jointly with any other person or persons for the purpose of inspecting and may inspect, examine or test any apparatus conduct of such inspections and tests and make available the licence, the station log or other records for examination by the inspecting officer.

(2) The licensee when called upon to do so by the Central Government shall arrange to forward the licence, the logbook, or any other record or date for examination by that Government.

## **XI. Powers to take possession of the Amateur Station and to order interception of message:**

(1) On the occurrence of any public emergency, or in the interest of the public safety, the Central Government or a State Government or any officer specially authorized in this behalf by the Central Government or a State Government may, if satisfied that it is necessary or expedient so to do, take temporary possession (for so long as the public emergency exists or the interest of the public safety requires the taking of such action) of the Amateur Station.

(2) On the occurrence of any public emergency or in the interest of the public safety, the central government or a State Government or any officer specifically authorized in this behalf by the Central Government or a State Government may, if satisfied that it is necessary or expedient so to do in the interests of the sovereignty and integrity of India, the security of the State, friendly relations with foreign states or public order or for preventing incitement to the commission of an offence, for reasons to be recorded in writing, by order, direct that any message of class of messages relating to any particular subject, shall not be transmitted or received or shall be intercepted by the station or shall be disclosed to the Government making the order or an officer thereof mentioned in the disclosed to the Government making the order or an officer thereof mentioned in the order.

(3) The licensee shall not be entitled to any compensation in respect of the exercise of the powers conferred by sub condition (1) and (2) of this condition.

**XII.** The licensee shall indemnify the Central Government against all actions, claims and demands which may be brought or made by any person, body corporate or company in respect of any injury arising from

any act licenced or permitted by the licence.

**XIII.** A copy of the Indian Wireless telegraphs (Amateur Service) Rules, 1978 shall be kept at the Amateur Station.

Table

[See Condition VI(6)]

Specimen Form of Log

Sl. No. of Contact	Date	Time	Frequency & Type of Emission & power input to final stage (FEP)	Station Called by	Station heard or worked (RST)	Report Received (RST)	Time of Termi-nating QSO	Time of Record Experiment & tests  /summary of communication	QSL Card (Sent/ received)	Initials

**ANNEXURE II**

Under the above rules, a licence may be granted, subject to certain conditions to a person, who is a citizen of India and not less than 18 years of age (subject to relaxation indicated at para 1 below) and who qualifies Amateur Station Operators's Examination Certificate of Proficiency issued by this Ministry i.e. (I) Radio Communication operator's GeneraLI Certificate; (ii) First or Second Class Radio Telegraph Operator's Certificate; (iii) The holder of a special radio telegraph Operator's Certificate may also be considered eligible for the award of Grade II licence.

The following categories of licences are issued:

The fees for examination are shown alongside:

- (i) Advance Amateur Wireless Telegraph Station Licence Rs. 25/-
- (ii) Amateur Wireless Telegraph Station licence Grade I Rs. 20/-
- (iii) Amateur Wireless Telegraph Station Licence Grade II Rs. 10/-
- (iv) Restricted Amateur Wireless Telegraph Station Licence Rs. 10/-
- (v) Shortwave Listeners Amateur Wireless Telegraph Station Licence Nil

The central government may grant to bonafide experimenters between the ages of 14 and 18 years, Amateur Wireless Telegraph Station Licenc Grade I and to those between the ages of 12 and 18 years, Amateur Wireless Telegraph Station Licence Grade II, Restricted Amateur Wireless Telegraph Station Licence or Shortwave Listeners Amateur Wireless Telegraph Station Licence.

The examination for the award of various categories of Amateur Wireless Telegraph Statoin Licence are held at various Monitoring Stations of this ministry, as per the syllabus contained in the above mentioned rules. **A person desiring to appear in these examinations should apply on the prescribed application form (enclosed) to the nearest monitoring station along with the prescribed examination fee. In no case the application may be forwarded to WPC, Ministry of Communications, New Delhi.**

The examination fee varies from Rs. 10/- to Rs.25/- depending upon the category of examination. After a decision is taken to grant the licence, an additional fee of Rs. 25/- to Rs.50/- as the case may be, will be required towards the grant of licence. **The fees are required to be paid in the form of bank draft obtainable from any branch of the State Bank of India and drawn in favour of Pay & Accounts Officer (Headquarters), Department of Telecommunications, New Delhi 110001 (code 0691).**

The particulars of the venue and date, etc. of the examination will be communicated to the candidates by the officer-in-charge of the concerned monitoring station on receipt of the complete application form with requisite fee.

Following should accompany the application:

1. Nationality Certificate/Character Certificate in the prescribed proforma enclosed.
2. 2 copies of photograph duly signed on front side. The size of the photograph must be 3x4 cms.
3. Examination fees, in the form of bank draft, of the appropriate amount. The draft should be obtained from any branch of State bank of India and drawn in favour of '**Pay & Accounts Officer (Headquarters), Department of Telecommunications**'. It should be payable at State Bank of India, New Delhi Main Branch (Code No. 0691).
4. Result Sheet, duly filled in (in duplicate).
5. Personal particulars (in quadruplicate) in the prescribed proforma.

**APPLICATION FROM AN INDIVIDUAL FOR A LICENCE TO ESTABLISH, MAINTAIN AND WORK AN AMATEUR WIRELESS TELEGRAPH STATION IN INDIA.**

**(See rules 6 & 8)**

1. Name (In Block letters): .....

(Last name) (First) (Middle)

2. Father's/Husband's Name and address : .....

3. (a) Address (Present) .....

(b)Address (Permanent) .....

4. ( a )Date of Birth ( b )Place of Birth ( c )Nationality ( d )Occupation

5. (a) Category of Licence applied for (b) exact location of the Station

6. (a) If you are exempted from appearing in any part of the examination, give details of your qualifications

(b) If you wish to appear for the qualifying examination, give the preferred centre and date of examination

Centre Month of Examination

(c) Do you hold any other licence earlier, if so give details

Licence No. \_\_\_\_\_ Call-sign, if any \_\_\_\_\_

(Duly filled in application form should be submitted to the concerned Wireless Monitoring Station only)

### **DECLARATION**

I hereby solemnly declare that the foregoing facts are true and correct and nothing is false therein and nothing material has been concealed therefrom. I also agree that in case any information given by me herein before is found false at a later date, the licence, if granted, will be cancelled.

I further solemnly give an undertaking that I will not either directly or indirectly divulge to any person, except when lawful authorized or directed to do so, the purport of any message which I may transmit or receive by means of any wireless apparatus operated by me or which may come to my knowledge in connection with the operation of said apparatus.

I have carefully read and understood the rules contained n the Indian Wireless Telegraphs (Amateur Service) Rules, 1978 and undertake to abide by them and observe the conditions of the licence. The licensed station shall not be made accessible to any unauthorized person at any time.

Signature of witness: Signature of applicant

Name (in block letters) Name (in block letters)

Address:

Date: Date:

Place:

Note :

1. An attested copy of birth certificate or school leaving certificate must be accompanied along-with the application.
2. Enclose a certificate in support of nationality in the prescribed Performa, indicated in Appendix III from one of the officers listed therein.

**APPLICATION FOR A LICENCE TO ESTABLISH, MAINTAIN AND WORK AN AMATEUR WIRELESS TELEGRAPH STATION BY AN AMATEUR RADIO SOCIETY OR CLUB OR A SCHOOL, COLLEGE OR AN INSTITUTE OR A UNIVERSITY IN INDIA**

(See rules 6 & 8)

1. Name and address of the Amateur Radio Society/Club/School/Institute etc.

2. Particulars of authorized official of the Society/Club/School etc. in whose favour licence is desired

Name Designation

Date of Birth Place of Birth Nationality Occupation

3. (a) Category of licence applied for (b) exact location of the station

4. Particulars of Amateur Wireless Telegraph Station Licence held by the authorized official

Category of Licence Licence No. Date of Issue

5. Particulars of the Amateur Radio Society or club, school etc.

(a) If registered, given its particulars:

(b) In case of school, college or institute, give the name of Board or University by which it is recognized.

(c) Give in brief its aims and objectives:

(d) If affiliated to any radio amateur organization, give its particulars:

(e) Give the names of office bearers:

(f) Mode of operation of the station including its normal hours of working :

6. Particulars of Apparatus to be used:

Category of Apparatus/ Manufacturer's name /Type No/ Frequency Range /RF power output/ Transmitter

Receiver :

Frequency Measuring Device :

**DECLARATION**

I hereby solemnly declare that the foregoing facts are true and correct and nothing is false therein and nothing material has been concealed therefrom. I also agree that in case any information given by me herein before is found false at a later date, the licence, if granted, will be cancelled.

I further solemnly give an undertaking that I will not either directly or indirectly divulge to any person, except when lawful authorized or directed to do so, the purport of any message which I may transmit or receive by means of any wireless apparatus operated by me or which may come to my knowledge in connection with the operation of said apparatus.

I have carefully read and understood the rules contained n the Indian Wireless Telegraphs (Amateur Service) Rules, 1978 and undertake to abide by them and observe the conditions of the licence. The licensed station shall not be made accessible to any unauthorized person at any time.

Signature of witness: Signature of applicant

Name (in block letters) Name (in block letters)

Address:

Date: Date:

Place:

Note :

1. An attested copy of birth certificate or school leaving certificate must be accompanied along with the application.
2. Enclose a certificate in support of nationality in the prescribed Performa, indicated in Appendix III from one of the officers listed therein.
3. Attach a copy of the rules and regulations or constitution.
4. Attach the minutes of the relevant meeting.

### **PERSONAL DETAILS OF THE APPLICANT**

(To be submitted with **three extra copies** on separate sheet)

1.Full Name (In Block letters): \_\_\_\_\_

2.Date & Place of Birth: \_\_\_\_\_

3. Age: \_\_\_\_\_ Years \_\_\_\_\_ Months.

4. Height: \_\_\_\_\_ cm

5. Colour of: (i)Eyes \_\_\_\_\_ (ii)Hair \_\_\_\_\_

6. Complexion: \_\_\_\_\_

7. Any special peculiarities of mark: \_\_\_\_\_

8. Present Address: \_\_\_\_\_



\_\_\_\_\_

9. Permanent home address: \_\_\_\_\_

\_\_\_\_\_

10. Nationality: \_\_\_\_\_

11. Occupation (Major work \_\_\_\_\_  
or profession for which you \_\_\_\_\_  
receive money or activity \_\_\_\_\_  
which occupies the \_\_\_\_\_  
majority of your time)

12. Father's name and home address \_\_\_\_\_  
(if dead, give last address)Aliases \_\_\_\_\_  
if any: \_\_\_\_\_

13. Type of license applied for: \_\_\_\_\_

14. Proposed location of station: \_\_\_\_\_  
(Details of house No., Street \_\_\_\_\_  
No., Road No.) \_\_\_\_\_

Dated: \_\_\_\_\_

Signature of the applicant  
(Full name giving expansion of initials)

**ANNEXURE III**  
**Nationality Certificate**

Certified that I have known Shri/Smt./Km. \_\_\_\_\_,  
Son/Daughter of Shri \_\_\_\_\_ for the last \_\_\_\_\_

Years and that to the best of my knowledge and belief he/she bears a good moral character. He/She is of \_\_\_\_\_ nationality.  
He/She is not related to me.

Address: Signature

NOTE:  
This certificate should be from one of the officers listed below:

1. Gazetted Officers of Central or State Governments.
2. Members of Parliament or State Legislatures.
3. Sub-divisional Magistrate/Officer.

4. Tehsildars or Naib/Deputy Tehsildars, authorized to exercise magisterial powers.

## ANNEXURE IV

**Licence No. [See rule 9]**

### GOVERNMENT OF INDIA

### MINISTRY OF COMMUNICAITON

### LICENCE TO ESTABLISH, MAINTAIN AND WORK AN AMATEUR WIRELESS TELEGRAPH STATION IN INDIA.

Having satisfied, by examination or otherwise, that Shri ..... possesses the requisite technical qualifications as prescribed under the Indian, Wireless Telegraphs (Amateur Service) Rules, 1978, the Central Government in exercise of the powers conferred under the authority of section 4 of the Indian Telegraph Act, 1885 (13 of 1885), hereby grant to him an ..... to establish, maintain and work a wireless telegraph transmitting and receiving station, detailed below, during the term of period commencing on the day of the date hereof and terminating on the .....19 ..... when this licence becomes invalid unless renewed further by way of a document showing the renewal of Licence.

The licence is governed by the Indian Wireless Telegraphs (Amateur Service) Rules, 1978, Particulars of the Station :

Location Call-sign

Issued by the Government of India in the

Ministry of Communication

New Delhi :

Dated :

**Deputy/Assistant Wireless**

**Adviser to the Govt. of India**

**Signature of Licencee**

**Signed by the Licencee**

**in the presence of ..... Date .....**

**Date :**

**Latest amendment to the Indian Wireless Telegraph (Amateur Service) Rules, 1978, vide Notification dated 4<sup>th</sup> October, 1985.**

In pursuance of the provisions of rule 13 of the Indian Wireless Telegraph (Amateur Service) Rules, 1978 the Central Government hereby authorises the following frequency bands, emission and power to the holder of Amateur Wireless Telegraph Station Licence. This supercedes the frequency bands, emission and power

prescribed in the Annexure-V to the above said rules in pursuance to Notification No, R-11014/14/82-L.R. dated 23<sup>rd</sup> May, 1983.

### ANNEXURE V

#### Frequency bands, emission and power

Category of Licence	Frequency bands	Emission	Maximum D.C. input power unless otherwise specified
<b>(a) Restricted Amateur Wireless Telegraph Station Licence. See Note (v) below.</b>	144-146 MHz	A3E, H3E, J3E, R3E, F3E	10 Watts (terrestrial service only authorised)
<b>(b) Amateur Wireless Telegraph Station Licence Grade II. See Note (vi) below.</b>	1820-1860 kHz* 3500-3700 kHz 3890-3900 kHz 7000-7100 kHz 14000-14350 kHz 18068-18168 kHz \$ 21000-21450 kHz 24890-24990 kHz \$ 28000-29700 kHz 144-146 MHz 434-438 MHz @	A1A, A3E, H3E, J3E, R3E  A1A, A2A, A3E, H3E, R3E, J3E, F1B, F2A, F3E	50 Watts  10 Watts (terrestrial service only authorised)
Category of Licence	Frequency bands	Emission	Maximum D.C. input power unless otherwise specified

<p><b>(c) Amateur Wireless Telegraph Station Licence Grade I. See Note (vi) below.</b></p>	<p>1820-1860 kHz*                      3500-3700 kHz                      3890-3900 kHz                      7000-7100 kHz                      14000-14350 kHz                      18068-18168 kHz \$                      21000-21450 kHz                      24890-24990 kHz \$                      28000-29700 kHz                      144-146 MHz                      434-438 MHz @                      1260-1300 MHz @ &amp;                      3300-3400 MHz</p>	<p>A1A, A2A, A3E, H3E, R3E, J3E, F1B, F2A, F3E, F3C, A3C, A3F</p> <p style="text-align: center;">-do-</p>	<p>150 Watts</p> <p>25 Watts for terrestrial service. Amateur Satellite Service is</p>
<p><b>(d) Advanced Amateur Telegraph Station Licence. See Note (i) below</b></p>	<p>@5725-5840 MHz @</p> <p>1820-1860 kHz*                      3500-3700 kHz                      3890-3900 kHz                      7000-7100 kHz                      14000-14350 kHz                      18068-18168 kHz \$                      21000-21450 kHz                      24890-24990 kHz \$                      28000-29700 kHz</p>	<p>A1A, A2A, A3E, H3E, R3E, J3E, F1B, F2A, F3E, F3C, A3C, A3F</p>	<p>permitted in the appropriate sub-bands in accordance with Radio Regulations and in those cases the maximum output RF power (e.i.r.p.) is 30 dbw.</p> <p>150 Watts</p> <p>50 Watts for terrestrial service. Amateur Satellite Service is permitted</p>

	144-146 MHz 434-438 MHz @ 1260-1300 MHz @ & 3300-3400 MHz @ 5725-5840 MHz @	-do-	in the appropriate sub-bands in accordance with Radio Regulations and in those cases the maximum output RF power (e.i.r.p.) is 30 dbw.
--	---	------	--

\* On primary shared basis as per the relevant provisions of Radio Regulations.

\$ The authorisation is on non-interference and non-protection basis.

@ On secondary basis as per the relevant provisions of Radio Regulations.

& 1260-1270 MHz for Earth to space satellite service only.

The above authorisation is subject to site clearance as per the procedure prescribed by the Standing Advisory Committee on Radio Frequency Allocation (SACFA) as applicable.

Note: (i) Following sub-bands of frequencies are authorised with enhanced R.F. power to holder of Advanced Amateur Telegraph Station Licence

3520-3540 kHz	All emissions as authorised	400 Watts
3890-3900 kHz		
7050-7100 kHz		
14050-14150 kHz		
14220-14320 kHz		
21100-21400 kHz		

- ii. For A3F emission, the transmission shall be restricted to call-sign of the station, location and other particular of the amateur station. They shall be limited to point to point test transmission employing a standard interlace and scanning with a bandwidth not more than 4 kHz.
- iii. DC input power is the total direct current power input to the final stage of the transmitter.
- iv. In case of Short Wave Listener's Amateur Licence, the holders are permitted to listen to all the bands authorised to Amateur Service.
- v. The syllabus for the examination of the Restricted Amateur Wireless Telegraph Station Licence shall be same as per Part I of Amateur Station Operator's Grade II examination.

(vi)The holder of Amateur Wireless Telegraph Station Licence, Grade II shall be entitled for authorisation of radio telephony emission on his providing proof of having made 100 contacts

with other Amateurs using

## G. Syllabus of Amateur Station Operator's Certificate (ASOC) Examination for the award of Amateur Station Operator's Licence

The ham radio licensing examination is conducted to ascertain that the person going to be a ham radio operator is equipped with the knowledge and proficiency which is necessary to communicate using a wireless transceiver without causing interference to the other radio communication services and as per agreements set up at the International Communication Meetings. The course covers basic electronics and radio theories as well as the existing national and international rules related to amateur radio communication in radiotelephony (voice) and radio telegraphy (Morse Code). The person who wants to become a ham should at the same time be able to show his proficiency in Morse Code sending and receiving. The Amateur Radio Operator's Certificate is awarded by the Wireless Planning and Coordination (WPC) Wing of the Ministry of Communication, New Delhi. The examination is conducted at the Wireless Monitoring Stations (The list of Wireless Monitoring Stations can be found in another booklet brought out by Vigyan Prasar entitled "Be a Ham! Talk to the World") located throughout the country. The examination is held for four different categories of licence. They are the :

**Advanced Grade Licence**

**Grade I Licence**

**Grade II Licence**

**Restricted Grade Licence.**

Anyone above 12 years of age can obtain Amateur Radio Station Operator's Licence after passing the examination/s mentioned above. **It is also possible to establish an Amateur Radio Club Station with a Grade-I licenced ham in charge of it.**

The application form for Amateur Radio Station Operator's Certificate Examination can be obtained from :

**The Assistant Wireless Advisor to the Govt. of India,  
Wireless Planning & Coordination (WPC) Wing, Amateur Radio Section,  
Ministry of Communications, Dak Bhavan,**

**Parliament Street, New Delhi-110001**

The application form can also be obtained from the Wireless Monitoring Station of the Ministry of Communications located nearest to your hometown. **The filled-in Application Form along with all other necessary documents should be sent to the Wireless Monitoring Station located nearest to your home town or where you wish to appear for the examination.**

## Syllabus

### Part-I

#### Section I

Radio Theory and Practice (**Applicants holding degree in telecommunication, or electronics and electrical communication, or a degree recognized by the central government as equivalent to the above degree shall**

**be exempted from appearing in SECTION I of the test).**

## **Section II**

National and International regulations applicable to the operation of amateur radio station and those relating to the working of station generally.

## **Part II - Morse Code**

### **Section I**

Morse code **receiving**.

### **Section II**

Morse code **sending**.

## **Detailed syllabus**

### **Part-I**

### **Section I : Radio Theory and Practice**

#### **Elementary electricity and magnetism**

Elementary theory of electricity, conductors and insulators, units, Ohm's law, resistance in-series and parallel, conductance, power and energy, permanent magnets and electromagnets and their use in radio work; self and mutual inductance; types of inductors used in receiving and transmitting circuits, capacitance; construction of various types of capacitors and their arrangements in series and/or parallel.

#### **Elementary theory of alternating currents**

Sinusoidal alternating quantities-peak, instantaneous, RMS, average values, phase; reactance, impedance; series and parallel circuits containing resistance, inductance, capacitance; power factor, resonance in series and parallel circuits; coupled circuits; transformers for audio and radio frequencies.

#### **Thermionic Valves**

Construction of valves; thermionic emission, characteristic curves, diodes, triodes and multi-electrode valves; use of valves as rectifiers, oscillators, amplifiers, detectors and frequency changers, power packs, stabilization and smoothing.

#### **Elementary theory and construction of semiconductor devices**

Diodes and Transistors.

#### **Radio receivers**

Principles and operation of TRF and superheterodyne receivers, CW reception, receiver

characteristics-sensitivity, selectivity, fidelity; adjacent channel and image interference; AVC and squelch circuits; signal to noise ratio.

### **Transmitter**

Principles and operation of low power transmitter; crystal oscillators, stability of oscillators.

### **Radio propagation**

Wavelength, frequency, nature and propagation of radio waves; ground and sky waves; skip distance; fading.

### **Aerials**

Common types of transmitting and receiving aerials.

### **Frequency measurement**

Measurement of frequency and use of simple frequency meters.

## **SECTION II : Radio Regulations**

(a) Knowledge of :

(i) the Indian Wireless Telegraph Rules, 1973; and

(ii) the Indian Wireless Telegraphs (Amateur Service) Rules, 1978.

(b) Knowledge of International Radio Regulations as relating to the operation of amateur stations with particular emphasis on the following:

**Designation of Emission,**

**Nomenclature of the frequency and wavelength,**

**Frequency allocation to amateur radio service,**

**Measures against Interference,**

**Interference and tests, Identification of stations,**

**distress and urgency transmissions,**

**Amateur Stations,**

**Phonetic alphabets and figure code.**

(c) Standard frequency and time signal services in the world.

(d) The following 'Q' codes and abbreviations which shall have meaning as assigned to them in the International Telecommunication Union (ITU) convention :

QRA, QRG, QRH, QRI, QRK, QRL, QRM, QRN, QRQ, QRS, QRT, QRU, QRV, QRW, QRX, QRZ, QSA, QSB, QSL, QSO, QSU, QSV, QSW, QSX, QSY, QSZ, QTC, QTH, QTR and QUM.

Telegraphic (Morse code) abbreviations: AA, AB, AR, AS, BT, C, CFM, CL, CQ, DE, K, KN, NIL, OK, R, TU,



VA, WA, WB.

The written examination for Grade II licence is of one hours duration. The maximum number of marks is 100. Candidates must secure at least 40 per cent in each section and 50 per cent in aggregate to pass. The syllabus for Grade I licence is the same as that for Grade II licence, but the written examination for Grade I licence is of two hours duration. The maximum number of marks is 100 and candidates must secure at least 50 per cent in each section and 55 per cent in aggregate for a pass.

## **Part II : MORSE CODE**

### **(a) Section I : Morse receiving** (Speed: 5 words per minute)

The test piece will consist of a plain language passage of 125 letters, five letters counting as one word. Candidates are required to receive for five consecutive minutes at the speed of 5 words per minute from a double headgear headphone receiver, international Morse code signals from an audio frequency oscillator keyed either manually or automatically. A short practice piece may be sent at the prescribed speed before the start of the actual test. Candidates will not be allowed more than one attempt in each test. The test may be written in ink or pencil but must be legible. Bad handwriting and over-writing will render a candidate liable to disqualification. More than five errors will disqualify a candidate.

### **(b) Section II : Morse Sending** (Speed: 5 words per minute)

The test piece will consist of a plain language passage of 125 letters, five letters counting as one word. Candidates are required to send on an ordinary key for five consecutive minutes at the minimum speed of five words per minute. A short practice piece may be allowed before the actual test. Candidates will not be allowed more than one attempt in the test. Efforts should be made to correct all errors. However, more than five uncorrected errors will disqualify a candidate. The accuracy of signaling, correct formation of characters and the correctness of spacing shall be taken into account.

A candidate is required to pass both in Part I and Part II. In the case of candidates qualifying in Part I only, the licence shall be restricted to radiotelephone operations in the VHF ham band only.

## **Morse Code test for Grade I**

### **Receiving**-(Speed: 12 words per minute)

The test piece will consist of a plain language passage of 300 characters which may comprise letters, figures and punctuation (punctuation are indicated below). The average words shall contain five characters and each figure and punctuation will be counted as two characters. Candidates are required to receive for five consecutive minutes at a speed of 12 words per minute. Other conditions are the same as applicable to Grade II Examination.

### **Punctuations**

Full stop, Comma, Semi-colon, Break sign (BT), Hyphen and Question mark.

### **Sending**-(Speed: 12 words per minute)

The test piece will be similar to Morse receiving test. Candidates are required to send for five consecutive minutes at a speed not less than 12 words per minute. Other conditions are the same as applicable to Grade II

examination.

A candidate is required to pass both in Part I and Part II simultaneously.

## **Advanced Amateur Station Operators' Examination**

### **Part I-Written Test**

#### **(a) Section 1: Radio Theory and Practice**

In addition to the syllabus prescribed for Grade II Examination, following items shall be included in the syllabus of Advanced Amateur Station Operators' Examinations :-

- (i) **Motors and generators:** Elementary principles and construction of alternators, motors and generators.
- (ii) **Alternating current:** Construction of transformers, transformer losses, transformer as a matching device.
- (iii) **Measuring instruments:** Moving coil and moving iron meters, frequency meters.
- (iv) **Semiconductor devices and transistors:** Elementary principles of conduction and construction, symbols, biasing methods.
- (v) **Power supplies:** Halfwave and fullwave rectifiers, smoothing and regulation, bridge rectifier.
- (vi) **Modulation:** Principles of frequency modulation.
- (vii) **Transmitters and receivers:** Elementary principles of transmission and reception of facsimile and television signals, elementary principles of transmitters and receivers employing single side band.
- (viii) **Propagation:** Characteristics of ionosphere and troposphere. Properties of different reflecting layers, optimum working frequency, day and night frequencies.
- (ix) **Aerials:** Principles of radiation, aerials for different frequency bands including aerials for microwave.
- (x) **Space communications:** Elementary principles of communication via satellite.

#### **(b) Section 2: Radio Regulations**

Syllabus is same as prescribed for Grade II Examination. The test is of 3 hours duration. The maximum number of marks is 100 and candidate must secure at least 50 per cent in each section and 60 per cent in aggregate for a pass.

### **Part II- Morse Code**

Syllabus is same as prescribed for Grade I Examination.

### **Part-III**

#### **Radio Theory and Practice**

## **A. Elementary Theory of Electricity & Magnetism**

## What is electronics?

Electronics is the field of manipulating electrical currents and voltages using passive and active components that are connected together to create circuits. Electronic circuits range from a simple load resistor that converts a current to a voltage, to computer central processing units (CPUs) that can contain millions of transistors. Electronic devices operate by the movement of electrons through conductors, e.g. wires, and electronic components.

## What are passive components?

Resistors, inductors, transformers and capacitors are called *passive devices*. They don't alter their resistance, impedance or reactance when alternating currents (ac) are applied to them.

## What are active components?

Vacuum tubes, diodes, transistors etc. are called active devices. They change their resistance or impedance when varying voltages are applied to them and as a result can amplify, rectify, modify or distort ac waveforms. Passive devices normally don't distort waveforms.

## Matter and electricity

Before going to discuss the different theories related to electricity and magnetism, we would like to give a brief idea about matter. All matter consist of molecules. A molecule can be defined as the smallest particle, which shows all the characteristics of a particular matter. For example, molecule of water is obtained by dividing a drop of water again and again until it can be divided and still be water. Further division of this water molecule will yield three particles which are not water. Molecule of water contains two atoms of hydrogen (H) and one atom of oxygen (O). Chemical combination of different atoms makes a molecule. An atom can be further divided into three particles known as protons and electrons and neutrons. Protons and electrons are the particles possessing electrical properties whereas neutron is electrically neutral. These particles can't be divided further.

**Electrons** are the **negatively charged** particles, which revolve around the positively charged **protons** (which constitute the nucleus of an atom along with neutrons). **Proton is about 1800 times heavier than electron.** There is always attraction between unlike charges. Because electron is much lighter than proton, hence it is pulled towards the proton. If the force of attraction is enough, then the electron comes too closer to the proton and both the particles together form a neutral particle to be known as neutron. **Atoms, of all matters, except hydrogen contains one or more neutron in their nucleus.**

The electrical charge of an electron can be explained with the help of an imagination that there exist lines of forces, which are outward pointing. Though the size & weight of electron and proton varies significantly, the negative field of an electron is just as strong negatively as the positive field of a proton is positive. Small though it is physically, the field near the electron is quite strong. The strength of the field varies inversely with the distance squared.

Though electrons and protons have different kind of charge in them, both have charges of equal magnitude. An electron (negatively charged) repels another electron, while a proton (positively charged) repels another proton. So the basic physical law states:

***"Like charges repel; unlike charges attract".***

## What is charge?

Charge is an amount of electrons. Its unit is coulomb (C) and symbol is 'q'. One coulomb is equivalent to  $6 \times 10^{18}$  electrons.

## What is current?

Atoms of a metal form a crystal lattice, and in the spaces between the lattice points free electrons move chaotically, wandering aimlessly here and there. But it is enough to connect a metal plate to the two poles of a voltage source for the electrons immediately to acquire an aim. They will move towards the positive pole of the battery, and an electric current will begin to flow in the metal. An electric current can also flow in a gas. A voltage applied across a gas-filled tube causes ionization of the gas: free electrons stream towards the plate with the positive potential, colliding with the atoms in their way and detaching electrons from their orbits. The positive ions move toward the opposite end of the tube. **Current is the rate of flow of charge, i.e., the number of coulombs flowing past a point per second. Its unit is ampere (A) or amp. One amp is equal to one coulomb per second.**

## What is voltage?

Voltage is also called potential (Potential is defined as the work required from some energy source in moving a unit positive charge between two points in an electric field), potential difference, potential drop, or electromotive force-EMF. It is the electronic potential energy between two points, and is the driving force that causes charge to flow. Its unit is volt (V). One volt is defined as the potential difference that requires one joule of energy to move one coulomb of charge. Voltage is always measured relative to some other point in a circuit, e.g. the potential across a resistor. Voltage measurement made at a single point in a circuit are made relative to the earth (ground), which is assigned an "absolute" voltage of zero.

## Types of electricity

### Direct Current (DC)

The current, which flows in one direction in a circuit. DC voltage has a fixed polarity (e.g. a battery or an electrical cell) and the magnitude of the current remains constant. In an electrical circuit, the flow of electric current is indicated by an arrow mark originating from the positive terminal of the battery towards the negative terminal of the battery. This is the conventional method of showing the direction of current flow. But the real direction of electron flow is from the negative terminal of the battery to the positive terminal.

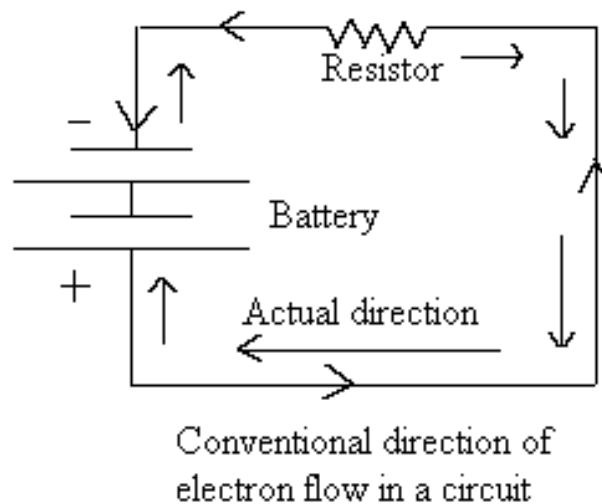

### Alternating Current (AC)

Alternating current flows first in one direction then in the opposite direction. The same definitions apply to alternating voltage. AC voltage switches polarity back and forth. AC voltage/current has a wave-form which

represent the frequency of the source. The wave-form of the household ac is known as the 'sine' wave. The magnitude of the A.C. voltage changes with time. AC is obtained from A.C. generators.

### Advantage of AC

Heat is developed in all type of electrical circuits due to the flow of electric current. The magnitude of the D.C. being constant produces more heat in a circuit compared to the heat produced by an A.C. In long distance transmission lines, large amount of power will be dissipated in the form of heat if D.C. is used which can be reduced by the use of A.C.

A.C. Voltage can be measured in four different ways.

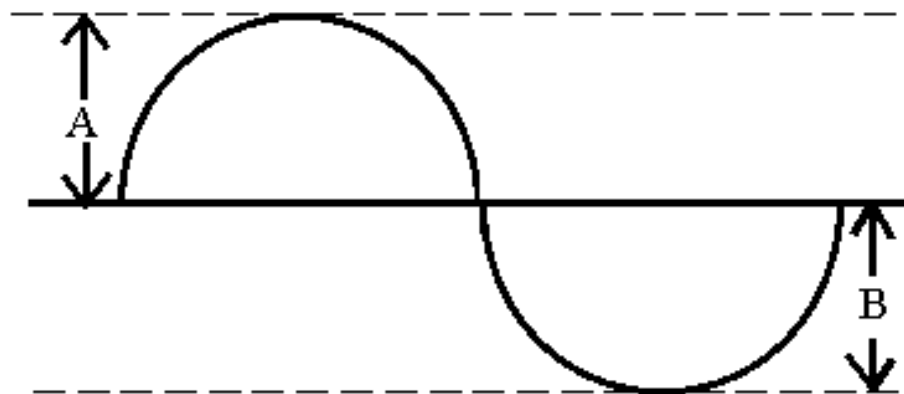

A Sine wave Cycle. The upper half denotes the positive cycle and the lower half denotes the negative cycle.

### Peak Voltage

The value or amplitude of an A.C. voltage never remains constant. With an initial voltage of zero, the amplitude rises to a peak value, after which it again falls back to zero. After reaching zero, the direction of the current changes and the voltage rises to its negative peak. Peak voltage measurement is necessary to ensure or know that the amplitude of the A.C. voltage does not exceed a limit.

### Instantaneous Voltage

It is also called the **average voltage**. The voltages if can be measured at different points of the half cycle of the sine wave will be the instantaneous voltages. But practically it is not possible. So one way to denote instantaneous voltage is to take the average voltage. In a sine wave A.C. voltage, the average voltage can be found out by multiplying the 'peak voltage' by a constant (value of the constant can be worked out to be equal to 0.367).

### Root-Mean-Square Voltage

Measuring an A.C. voltage involves the use of a meter which measures AC Voltage in terms of how much DC voltage it would take to have the same effect in a circuit. Since during most of the cycle the AC has a value less than the value at its peak, or for that matter, than that of a constant DC voltage, it will not be able to produce as much heat (in a heating element) as produced by the same amount of DC voltage. Power being proportional to either  $E^2$  or  $I^2$  ( $P=E^2/R=I^2R$ ), if all the instantaneous values of a half cycle of sine-wave current (or voltage) are squared and then the average, or mean, of all the squared values is found, the square root of this mean value will be 0.707 of the peak value. This root-mean-square, or rms, value represents how effective a sinusoidal AC will be in comparison with its peak value.

To determine a peak value of AC that will be as effective as a given DC, it is necessary to multiply the effective value given by the reciprocal of 0.707 (1/0.707), which is 1.414.

In a domestic AC supply, 230 volts is actually the effective voltage,  $V_{\text{eff}}$ , which is  $230 \times 1.414$ , or nearly 325 Volts peak.

## Magnetism

### What is a magnet?

A piece of iron, nickel, cobalt, steel, alloy (e.g. alloy made from non-magnetic copper, manganese and aluminum) etc. usually in the form of a bar having properties of attracting or repelling iron is called a magnet. But what gives it its force is not completely known. One of the theories to describe magnetism is the-"Theory of Domains". It says that materials that can be made into magnets have many tiny crystal like structures called domains. Each domain is made up of many atoms. Each domain has a small magnetic force of its own. When the material is not magnetized, the domains are haphazardly arranged-pointing in all directions-so that their tiny forces cancel each other. To make the material into a magnet, the domains need to be lined up so that their individual magnetic forces all help each other pull the same way. When *most* of the domains line up, the magnet becomes strong. When all of the domains line up in one direction, the magnet is saturated. It cannot be made any stronger regardless of how much you try to magnetise it. In a magnetic bar, there are two poles: North and South. They are marked as 'North' and 'South' poles because, when the magnetic bar is suspended horizontally, one of the ends will always point towards the Earth's geographical north and the other pole towards the Earth's geographical south. This is because of the fact that the Earth itself behaves like a huge magnet. In a magnet, the like poles repel and the unlike poles attract-a reason for the specific alignment of the magnetic bar. The magnetic bar is surrounded by the invisible lines of forces which originate from the 'North' pole and terminate in the 'South' pole.

### Ferro-magnet

Iron, nickel and cobalt (including the alloy mentioned above) are considered ferromagnetic. Ferro-magnetic materials are difficult to be converted to magnet but once magnetized under the influence of another magnetic field, they cannot be completely demagnetized. Ferromagnetic materials are used to make permanent magnets. **One of the strongest permanent magnets is a combination of iron, aluminum, nickel and cobalt called "Alnico".**

### Paramagnet

Materials which get demagnetized once the external magnetic field is removed are paramagnetic.

### Use of Permanent magnets in Electronics

Permanent magnets are used in electronics to make electric meters, headphones, loudspeakers, radar transmitting tubes etc.

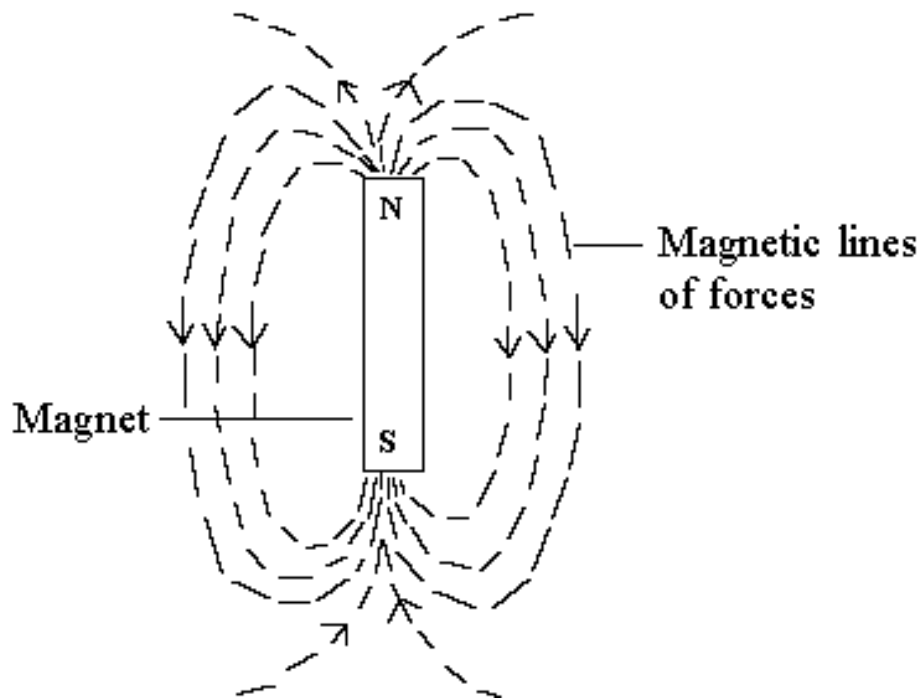

Electricity and electronics cannot be discussed by leaving apart 'magnetism' separately.

## Resistors

### What are resistors?

Resistors are load elements that dissipate current into heat. They are used in circuits to adjust voltages.

Resistance (R) is the retarding force in a material that impedes the flow of current. The potential (E) needed to achieve a current (I) through a material that behaves linearly, e.g. conductors and resistors, is given by Ohm's law:

$$E=IR$$

Where E=emf (in volts, V)

I=intensity of current (in amperes, A)

R=Resistance (in ohms,  $\Omega$  )

So, if we know any two values, we can find out the other value. The above formula can be rearranged as shown below:

$$I=\frac{E}{R} \text{ or Current in amperes= volts/ohms}$$

From this formula, it is evident that-"**Current varies directly as the voltage and inversely as the resistance**".

The formula can also be arranged to find out the resistance in a circuit if the voltage and current are known.

$$R=\frac{E}{I} \text{ or Resistance in ohms= volts/amperes}$$

### Practical Resistors

The resistance of a material depends on four physical factors:

(1) The **type of material** from which it is made. For example copper and silver are very good conductors of electric current, but iron is six times lesser in its conductivity than them.

(2) The **length** (greater the length greater is the resistance).

(3) **Cross-sectional area** (greater the cross-sectional area larger the amount of free electron implying lesser resistance).

(4) **Temperature** (except for carbon and other semiconductor materials).

So each material has a specific resistance inherent in them. **The specific resistance of a material is the number of ohms in a 1 foot long 0.001 inch diameter** round wire of that material at room temperature. Silver has the least specific resistance, i.e.  $9.75 \Omega$  and nichrome is an alloy, which has specific resistance as high as  $660 \Omega$ .

### Wire-wound resistor

Nichrome or german silver wires are wound on a tubular ceramic form to make wire-wound resistor.

### Carbon resistor

Powdered carbon is mixed with a binding material and baked into small, hard tubes with wire attached to each end to make carbon resistors. The percentage of carbon in the mixture determines the resistance value in ohms.

### Colour codes of resistors

Carbon resistors are colour coded to indicate their values. Each resistor has four colour bands on its body. The first band (the band which is nearest to the end of the resistor) is the first number. The second band is the second number. The third band is the multiplier, i.e. number of zeros following the second number.

Colour	Band1	Band2	Band3
Black	0	0	
Brown	1	1	0
Red	2	2	00
Orange	3	3	000
Yellow	4	4	0000
Green	5	5	00000
Blue	6	6	000000
Violet	7	7	0000000
Gray	8	8	00000000
White	9	9	000000000



Resistors having values lower than  $10\ \Omega$  have three colour bands. The third band is either golden or silver in colour. A golden band indicates that the first two numbers are to be multiplied by 0.1. A silver band indicates multiplication by 0.01. The tolerance of three band resistors is 20%. If the golden or silver band is the fourth band respectively, then they indicate a tolerance of 5% and 10% respectively.

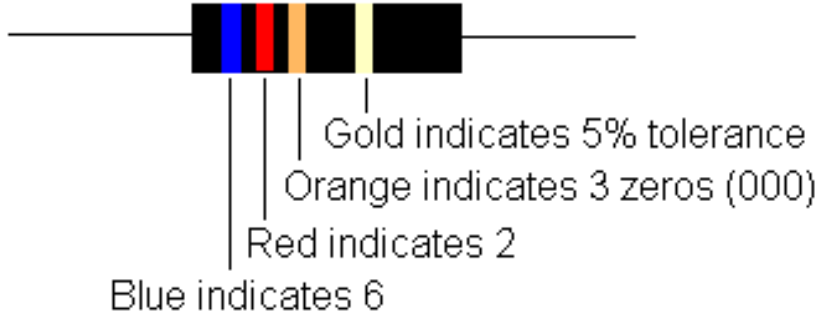

The value of this resistor is  $62000\ \Omega$  or  $62\ \text{k}\Omega$

### Questions:

1. A circuit has a resistance of 100 ohms and voltage applied across the circuit is 20 volts. What is the amount of current flowing through it?

We have,  $I = \frac{E}{R}$  or  $I = 20/100 = 0.2\ \text{A}$  (ampere) or 200 mA (milliampere)

2. Find out the voltage required to produce 3 A of current through a  $50\ \Omega$  (ohms) resistor.

We have,  $IR = E$  or  $3 \times 50 = 150\ \text{V}$  (volts)

### Power and Energy

As mentioned above, heat is developed in the load resistor as a result of current flowing through it. In absence of the load, a battery despite having the electro motive force (EMF), cannot produce movement of electrons and no electrical work is accomplished. When there is a load across the battery, movement of electrons take place. The product of the EMF (in volts) and movement of electrons (in amperes) gives us the amount of electrical work accomplished whose unit is watt (W).

$$P = EI$$

Where P=power (in watts, W)

E=emf (in volts, V)

I=current (in amperes, A)

So, 1 V causing 1 A to flow through a  $1\ \Omega$  resistor produces 1 W of power.

The above formula can also be expressed as

$$P = EI = (IR)I = I^2R \text{ (because the ohm's law states: } E = IR)$$

Or

$$P = EI = E\left(\frac{E}{R}\right) = \frac{E^2}{R} \text{ (because the ohm's law states: } I = \frac{E}{R})$$

**Questions:**

1. Find out the heat dissipated by a 50  $\Omega$  resistor when 0.25 A of current flow pass through it.

We have,  $P=I^2R$  or  $P=0.25^2 \times 50=0.0625 \times 50=3.125$  W

2. Find out the power dissipated by a 10,000  $\Omega$  resistor connected across a voltage source of 250 V.

We have  $P=E^2/R=250^2/10,000=6.25$  W

3. Find out the maximum voltage that may be connected across a 20 W, 2000  $\Omega$  resistor.

We have,  $P= E^2/R$

Or ,  $E^2=PR$

Or,

$$E=\sqrt{PR}$$

Or,

$$E=\sqrt{20 \times 2000}$$

$E=632.46$  V

4. Find out the maximum current that can flow through a 100  $\Omega$  1 W resistor.

We have,

$$I=\sqrt{\frac{P}{R}}$$

Or,

$$I=\sqrt{\frac{1}{100}} = 0.1 \text{ A or } 100 \text{ mA}$$

**What are conductors?**

Matters which allow the flow of electric current through them are called conductors. Metals are known to be good conductors, with copper and silver among the best. The conductivity of a particular material depends on the number of free electrons present in it. A conductor may be a very good conductor, a fairly good conductor or a poor conductor. So, a greater conductivity or conductance implies lesser resistance and a lesser conductivity implies greater resistance. So, conductance (conductance is expressed in siemens, S) and resistance (R) are the same thing but from opposite viewpoints. They are said to be reciprocal of

each other, i.e.

$$R=1/S \text{ or } S=1/R$$

So the Ohm's law can be expressed in terms of conductance by using  $1/S$  in place of  $R$  in the three formulas:

$$E=IR=I(1/S) \text{ or } E=I/S$$

$$I = \frac{E}{R} = \frac{E}{1/S} = E\left(\frac{S}{1}\right) \text{ or } I=ES$$

$$R = \frac{E}{I} \text{ or } \frac{1}{S} = \frac{E}{I} \text{ or } SE=I \text{ or } S = \frac{I}{E}$$

### Resistance in series and parallel

The circuit in Fig1 is a simple circuit with one load or resistor across a voltage source (e.g. a battery)

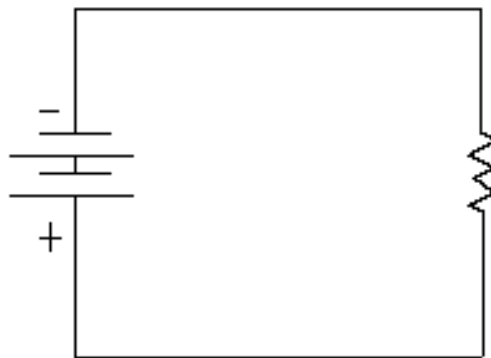

Fig. 1 A simple circuit with one resistor and a battery

The circuit shown in Fig.2 is a **series circuit** where three resistors are connected one after another and as evident from the diagram, there is only path through which current flows.

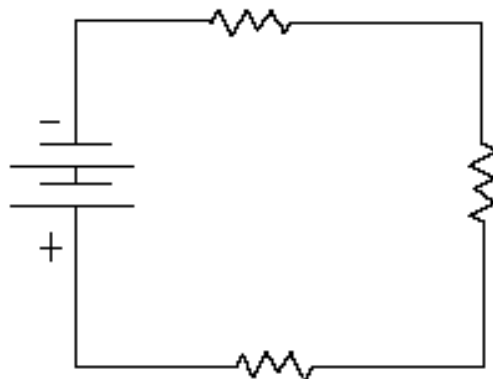

Fig. 2 A series circuit with three resistors in series

The circuit shown in Fig 3 is a parallel circuit where each resistor has its independent path for the flow of

current from the same source of voltage.

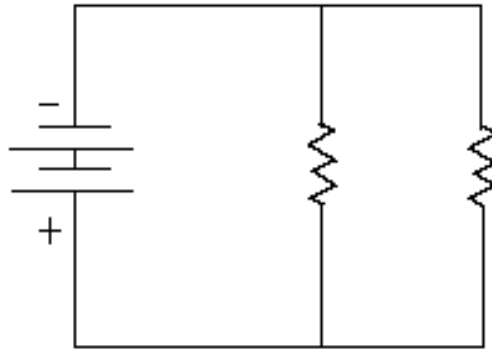
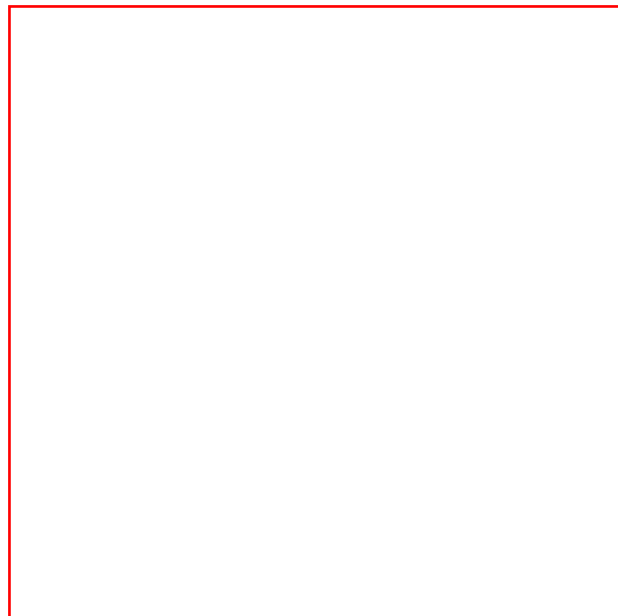

Fig.3 A parallel circuit with two resistors in parallel

The circuit shown in Fig 4 consists of two batteries and three resistors in series. In a series circuit the same amount of current flows through all parts of each circuit. The resistors are connected in series to obtain a greater resistance and it is equal to the sum of the values of each resistor, i.e.  $40\ \Omega$ . Two batteries are connected in series in this circuit to obtain the highest possible voltage which is the sum of the values of each battery, i.e.  $20\ \text{V}$ .



From the Ohm's law, the current flowing through this circuit will be:

$$I = \frac{E}{R} \text{ or } I = \frac{20}{40} = 0.5\ \text{A}$$

We should be careful while connecting batteries in series, because, the maximum current possible through the circuit is no greater than the greatest current that the weakest battery can deliver. If one of the batteries in the above example is weaker than the other and capable of passing only, say,  $0.2\ \text{A}$ , it will be overworked, may overheat and the voltage across the terminal will drop.

In this type of circuit, the voltage that can be obtained across each resistor is called the 'Voltage drop'. From the Ohm's law, the voltage across each resistor can be calculated. The voltage drop across the  $30\ \Omega$  resistor is  $15\ \text{V}$  ( $0.5 \times 30$ ) and the voltage drop across the  $5\ \Omega$  resistor (each) is  $2.5\ \text{V}$ . Thus the sum of the voltage-drops is equal to the source voltage ( $2.5 + 2.5 + 15 = 20\ \text{V}$ ).

## Internal Resistance of batteries

The battery might possess an internal resistance which is to be considered while calculating the various quantities in a circuit. If a 10 V battery has  $1\Omega$  internal resistance and connected across a  $9\Omega$  load resistor, the amount of current flowing through the circuit would be 1 A. A voltage drop of 1 V will take place inside the battery and hence the 10 V battery will produce only 9 V across its terminals when connected to the  $9\Omega$  load. When the circuit is open (no currents flowing through it), the voltage across the battery would be 10 V.

## Resistors in parallel circuit

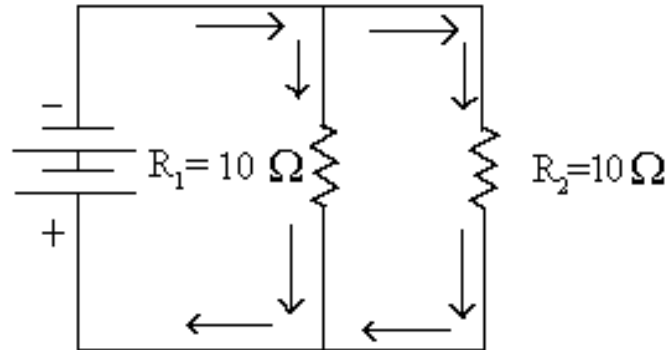

Fig. 5 A parallel circuit with two resistors in parallel

The circuit shown above is a circuit where two resistors are connected in parallel across the voltage source. Obviously, there are two paths for the flow of current. One part of the current flows through  $R_1$  and the other part flows through  $R_2$ . Since total conductance  $S_t$  of a circuit is equal to the sum of all the conductances connected in parallel, the formula can be expressed as:  $S_t = S_1 + S_2$

$$\text{Or } S_t = 1/R_1 + 1/R_2$$

$$\text{Or } 1/R_t = 1/R_1 + 1/R_2$$

The above equation is made into a pair of fractions by placing a 1 over both sides,

$$\frac{1}{1/R_t} = \frac{1}{1/R_1 + 1/R_2}$$

$$\text{or, } R_t = \frac{1}{\frac{1}{R_1} + \frac{1}{R_2}} = \frac{R_1 R_2}{R_1 + R_2}$$

$$\text{in the above circuit, } R_t = \frac{10 \times 10}{10 + 10} = 5\Omega$$

## Calculation in a complex circuit

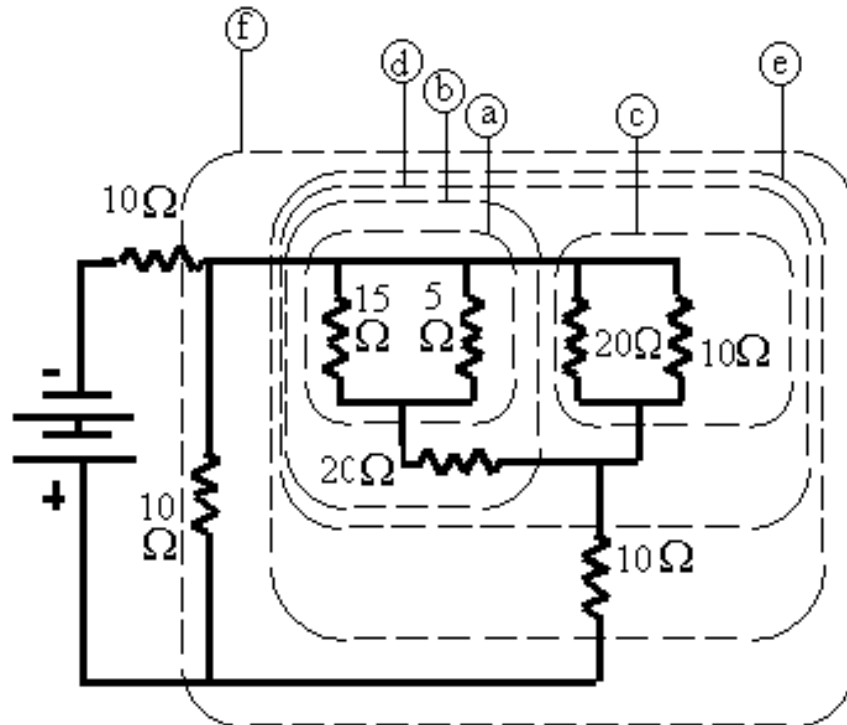

Fig. 6 A complex circuit

The circuit shown above seems to be a complex circuit. By looking at the arrangement of the resistors, their values can be computed in simple steps. As indicated above, calculate as per the steps shown [e.g. step (a), step (b).....]

**Step (a):**  $15\Omega$  &  $5\Omega$  resistors are arranged in parallel imparting a value equivalent to  $3.5\Omega$

**Step (b):**  $3.5\Omega + 20\Omega = 23.5\Omega$  (arranged in series)

**Step (c):**  $6.67\Omega$  (arranged in parallel)

**Step (d):**  $23.5\Omega$  &  $6.67\Omega$  are arranged in parallel or the equivalent value

### What are insulators?

The materials which do not allow the flow of electric current through them are called insulators. Glass, porcelain, dry air and dry wood are well known insulators.

## Inductors

### Self Inductance

Self inductance is the property of a circuit whereby a change in current causes a change in voltage. Self-inductance is also more simply known as inductance. If 'L' is the inductance, then increasing the value of 'L' increases the amount of voltage that is induced in response to a change in current. Decreasing the value of 'L' decreases the amount of voltage that is induced in response to a change in current.

**Inductance** is measured in units of **Henries (H)**. Commonly used engineering units for inductance are-henry (1 H), millihenry (1mH=1 x 10<sup>-3</sup> H) and microhenry (1 μ H=1x 10<sup>-6</sup> H).

**One henry is the amount of inductance that is required for generating one volt of induced voltage when the current is changing at the rate of one ampere per second.**

Inductance is the property of a coil when it is subjected to AC voltage. It results from the fluctuation of the current flowing through the circuit. When the current through the coil builds up, an expanding magnetic field also builds up cutting the turns of the coil resulting in the formation of a counter voltage in the coil which opposes the flow of the original current. This property of the coil is known as inductance. Since DC voltage remains constant (except for the instant when the circuit is closed, i.e. the instant when the switch is made on), there is no fluctuation in the magnetic lines of force produced across the turns of the coil and counter voltage is not generated. So a coil offers very negligible resistance (that due to the physical resistance) to the flow of DC current.

### Inductive reactance

Inductive reactance is the opposition to AC current flow that is caused by the presence of an inductor in the circuit. The symbol for inductive reactance is  $X_L$ . The unit of measure for inductive reactance is ohms ( $\Omega$ ). The amount of inductive reactance in a circuit is proportional to the *applied frequency (f)* and the *value of the inductor(L)*.

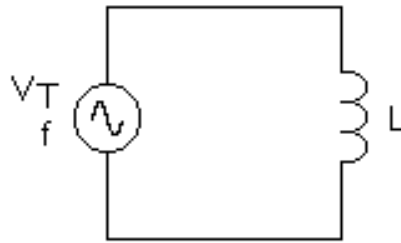

Inductive reactance is an AC version of resistance. In fact, Ohm's Law can be used by substituting  $X_L$  for R.

$$V_L = I_L X_L$$

Where  $V_L$  is the voltage across the inductor in volts,  $I_L$  is the current through the inductor in amperes,  $X_L$  is the amount of inductive reactance in ohms.

The equation for calculating the amount of inductive reactance in an ac circuit is given by:

$$X_L = 2\pi fL$$

The total inductive reactance of a series  $X_L$  circuit is equal to the sum of the individual reactances.

### Inductive reactance in series

$$X_{LT} = X_{L1} + X_{L2} + X_{L3} + \dots + X_{Ln}$$



Where  $X_{LT}$  is the total inductive reactance and  $X_{L1}$ ,  $X_{L2}, \dots, X_{Ln}$  etc. are the values of individual reactance.

### Inductive reactance in parallel

$$X_{LT} = 1 / (1/X_{L1} + 1/X_{L2} + 1/X_{L3} + 1/X_{Ln})$$

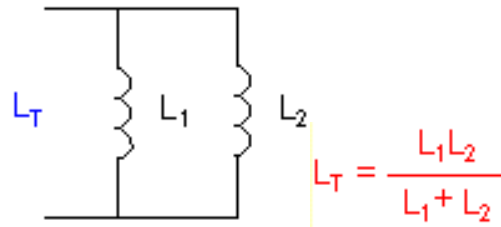

Inductive reactance is an AC version of resistance. In fact, you can use Ohm's Law by substituting  $X_L$  for  $R$ :

$$V_L = I_L X_{Ls}$$

where:

$V_L$  is the voltage across the inductor in volts

$I_L$  is the current through the inductor in amperes

$X_L$  is the amount of inductive reactance in ohms

The amount of inductive reactance ( $X_L$ ) changes proportionally with the applied frequency ( $f$ ):

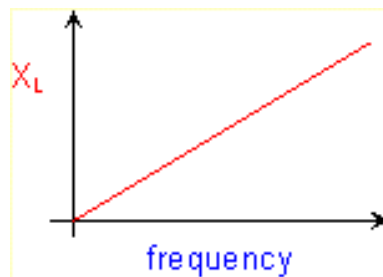

-Increasing the value of  $f$  causes  $X_L$  to increase.



-Decreasing the value of  $f$  causes  $X_L$  to decrease.

The amount of inductive reactance ( $X_L$ ) changes proportionally with the value of inductance ( $L$ ):

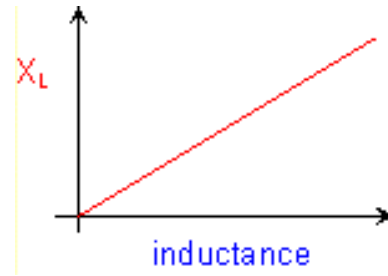

-Increasing the value of  $L$  causes  $X_L$  to increase.

-Decreasing the value of  $L$  causes  $X_L$  to decrease.

### Questions:

1. What is the value of inductive reactance for an 0.1 H coil that is operating at 1 kHz?

Ans: 628 W

Use the basic equation:  $X_L = 2\pi fL$

2. What value inductor is required for producing an inductive reactance of 10 W at 1.8 kHz?

Ans: 88.5 mH.

Use this form of the basic equation:  $L = 1 / (2fX_L)$

3. At what frequency will a 150 mH inductor have an inductive reactance of 150 W?

Ans: 159 Hz

Use this form of the basic equation:

$$f = 1 / (2 LX_L)$$

4. What is the total inductive reactance of this circuit when  $X_{L1} = 150$  W and  $X_{L2} = 75$  W?

Ans: 225 W

### Equation to find out inductive reactance in a circuit with a number of inductors in parallel

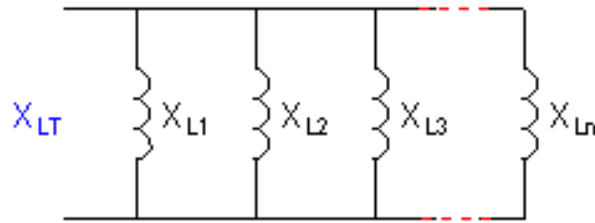

Use one of these inverse equations to determine the total inductive reactance of a parallel inductor circuit:

$$X_{LT} = \frac{1}{\frac{1}{X_{L1}} + \frac{1}{X_{L2}} + \frac{1}{X_{L3}} + \dots + \frac{1}{X_{Ln}}}$$

or

$$\frac{1}{X_{LT}} = \frac{1}{X_{L1}} + \frac{1}{X_{L2}} + \frac{1}{X_{L3}} + \dots + \frac{1}{X_{Ln}}$$

where:

$X_{LT}$  = total inductive reactance

$X_{L1}$ ,  $X_{L2}$ ,  $X_{L3}$ ,  $X_{Ln}$  = values of the individual reactances

The procedure for finding the total inductive reactance of a parallel inductor circuit is identical to finding the total resistance of a parallel resistor circuit.

The total reactance of two inductors in parallel can be found by applying the product-over-sum formula:

$$X_{LT} = \frac{X_{L1} X_{L2}}{X_{L1} + X_{L2}}$$

## Capacitor

Capacitor is a device used to store electrical energy and then release it as current into the circuit. Its property is just the reverse of an inductor. The capacitance of a capacitor is measured in Farad.

A capacitor has a capacitance of 1 Farad if a 1 Volt difference in potential results in the storage of 1 coulomb of charge.

1 coulomb =  $6.28 \times 10^{18}$  electrons

The capacitance is,  $C=Q/E$ ,

Where C is capacitance in farads,

Q is the charge in coulombs,

E is the voltage in volts.

Practically farad is a large unit. The smaller units are micro farads ( $\mu\text{F}$ ) and Pico farads (PF).

$$1 \text{ Micro farad} = \frac{1}{1,000,000} \text{ farad}$$

$$1 \text{ Pico farad} = \frac{1}{1,000,000,000,000} \text{ farad}$$

When two metallic plates or conductors are separated by an insulator, also known as a dielectric, they behave like a capacitor. The conductors can be long or short piece of metal plate or any other conducting material. The insulator between the two conductors which is known as dielectric can be air, mica, wax-impregnated paper ceramic etc. The properties of a capacitor:

1. It stores energy in the form of electrical field
2. Capacitance is the property of an electric circuit that tends to oppose a change in voltage.
3. It passes A.C. and blocks D.C.

### Functioning of a capacitor

A capacitor when connected across a voltage source, an electrostatic field builds up between the metallic plates. The field builds up due to the accumulation of electrons on the negative plate and release of electrons from the positive plate until the capacitor voltage reaches its maximum. The capacitor will be in this charged state as long as it is connected to the voltage source. After removal of the voltage source, the capacitor can not loose its charge (theoretically, a perfect capacitor would hold the charge forever, but in practical, some of the charges leak out), unless, both the plates are not connected with the help of a conducting path. When there is a conducting path, electrons from the negatively charged plate flows to the positive plate until both the plates are neutralized.

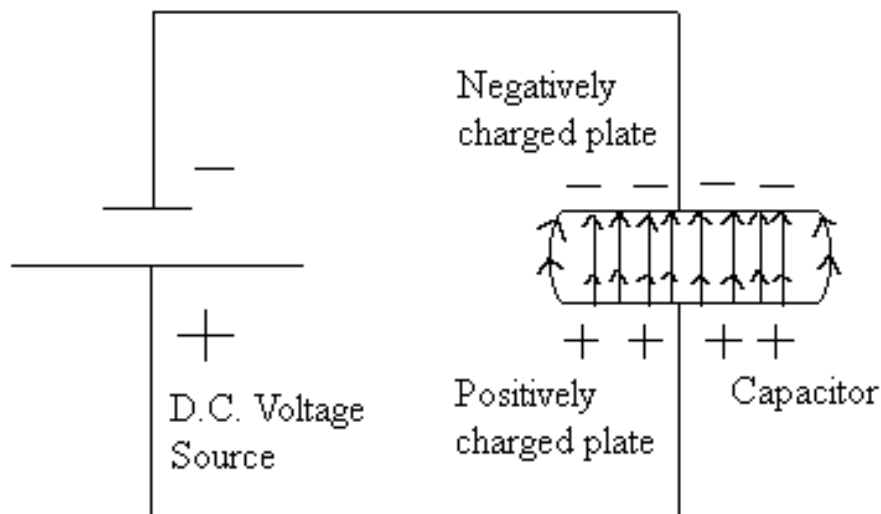

### Capacitor in a DC Circuit

In DC circuits, the capacitor will allow current to flow till it becomes fully charged, however since no current can flow through the dielectric material of the capacitor, no current flows after the capacitor gets fully charged.

### Capacitor in an AC Circuit

The AC Voltage or current is fluctuating in nature. It is not only fluctuating but also changing the direction of flow, i.e. the polarity of the AC voltage source keeps on changing resulting in a charging and discharging of the

capacitor. Unlike a DC circuit, here, current will continue to flow in the circuit (though the electrons don't cross the dielectric material of the capacitor).

### Capacitor in a varying DC circuit

If the voltage source is a varying DC, then also there is continual charging and partial discharging of the capacitor resulting in an AC current flowing through the circuit. In fact, the capacitor blocks the DC, but pass the AC component.

### Factors that affect capacitance

- 1. Area of plates :** The larger the plates, the higher its capacity to store charges, i.e. **capacitance is directly proportional to the plate areas.**
- 2. Space between the plates:** The closer the plates, higher is the capacity to hold charges, because, the electrostatic pull on the electrons collected at the negative side of the voltage source will be more. **Capacitance is inversely proportional to the spacing between plates.**
- 3. Type of dielectric used:** Some materials are more dielectric than the others. Vacuum is the basic dielectric with which other materials are compared. It is said to be having a dielectric constant of 1. The dielectric constant of air is slightly more than this (1.0006). Dielectric constant is the ability of a material to permit the establishment of electric lines of force between oppositely charged plates. A dielectric (other than air) makes the positively charged surface of a capacitor repel more free electrons and negatively charged surface accept more electrons than when air is dielectric, thus increasing the capacitance. The dielectric constant of mica ranges from 5 to 9. Dielectric constant of glass is 4.2. **Capacitance is directly proportional to the dielectric constant.**

A formula to determine the capacitance of a two-plate capacitor is:

$$C_{pF} = \frac{0.225 KA}{S}$$

Where

C= Capacitance in pF

K= dielectric constant

A= area of one of the plates, in inch<sup>2</sup>

S= spacing between plates, in inches

The above formula is valid for a two plate capacitor. For a multiplate capacitor, the formula is:

$$C_{pF} = \frac{0.225 KA(N-1)}{S}$$

Where N=number of plates in the capacitor

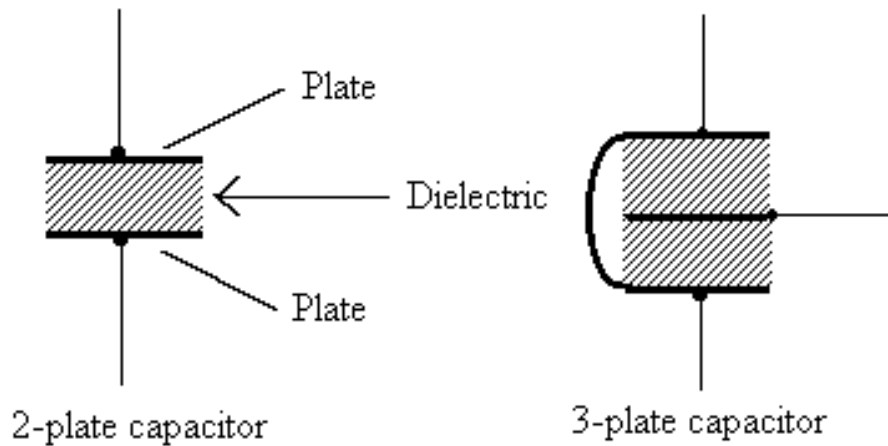

It is seen that a 3-plate capacitor has twice the plate area exposed and thus twice the capacitance.

### Quantity of charge in a capacitor

The quantity of charge in a capacitor can be found from the formula:

$$Q=CE$$

Where

Q = charge, in coulombs (C)

C = capacitance, in F

E = voltage, in V

If a 0.1 $\mu$ F capacitor is charged by a 10 V source, the electron difference will be:

$$Q=0.000001 \times 10 = 0.000001 \text{ C or } 10^{-6} \text{ C}$$

$$10^{-6} \text{ C} = 6.25 \times 10^{18} \times 10^{-6} = 6.25 \times 10^{12} \text{ electrons}$$

If the charged capacitor is disconnected from the voltage source, it will still retain the electron difference on its plates (assuming that there is no leakage). Now, if a similar uncharged capacitor is connected across the charged capacitor, electrons flow from the charged to the uncharged capacitor and it will get charged to 5 V as a result of distribution of half amount of electrons into it. Since the other capacitor lost half of its electrons, its voltage will be reduced to 5 V (now, both the capacitors will be having a voltage of 5 V each) from 10 V. If both the capacitors are reconnected in series, the total voltage-drop across them would become 10 V.

### Capacitive Reactance

Capacitive reactance is the resistance offered by a capacitor to the flow of AC through it. It is measured in ohms (O). The formula to calculate capacitive reactance in a circuit is:

$$X_c = \frac{1}{2\pi fC}$$

Where  $X_c$  = reactance, in Ohms

$f$  = frequency, in Hz

$C$  = capacitance, in F

**Questions:**

1. Find out the reactance of a 0.002  $\mu$ F capacitor to a frequency of 2,000 kHz.

Solution:

$$X_c = \frac{1}{2\pi fC} = \frac{1}{6.28 (2,000,000)0.000000002} = \frac{1}{0.02512} = 39.81 \Omega$$

**Capacitors in parallel**

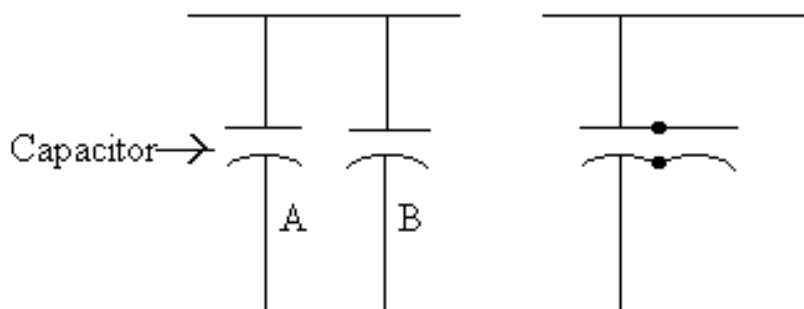

Two similar capacitors have twice the capacitance of one alone

Capacitors can be connected in parallel to obtain a greater value. The formula is:

Total capacitance of capacitors in parallel,  $C_t = C_1 + C_2 + C_3 + \dots + C_n$

While connecting the capacitors in parallel, it should be noticed that the voltage applied on them does not exceed the voltage rating of the capacitor with the minimum voltage rating.

**Capacitors in series**

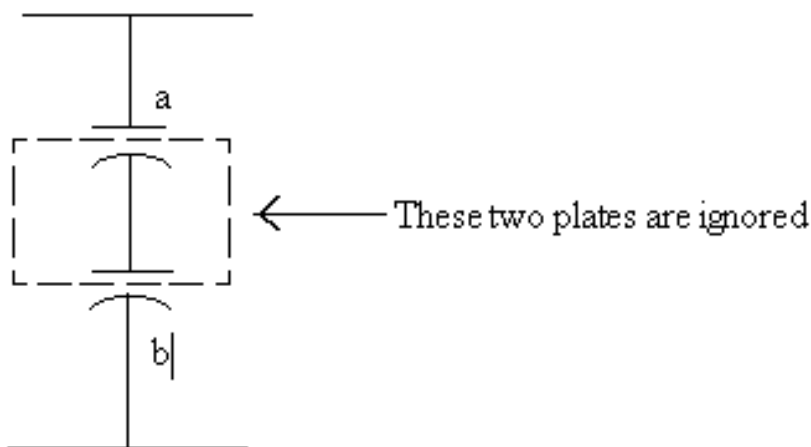

As shown above, when two capacitors are connected in series, the bottom & top plates of the respective capacitors are ignored and consequently combined effect of two capacitors of equal value is to simulate a single capacitor with half the value of a single capacitor, i.e. if two 10  $\mu$ F capacitors are connected in series as shown above, we will get an effective capacitance of 5  $\mu$ F. This is because the circuit sees only two plates (plate a & b)

with a dielectric distance of twice that of a single capacitor (capacitance decreases when distance between plate increases). It is to be noted that when capacitors of different voltage ratings are connected in series, the voltage that can be applied to them can be equal or less than the total voltage obtained by adding voltages of each capacitor, alternatively, we can say that when capacitors in series are connected across voltage source, the sum of the voltage-drops across each of them will always equal the source voltage.

The formula to calculate the total capacitance of a number of capacitors connected in series is:

$$C_t = \frac{C_1 \times C_2 \times C_3 \times C_n}{\frac{1}{C_1} + \frac{1}{C_2} + \frac{1}{C_3} + \frac{1}{C_n}}$$

### Types of capacitors

There are fixed value capacitor as well as variable value capacitors available for electronics work. Paper, mica, ceramic and polyester capacitors have fixed values.

#### Paper capacitor

Paper capacitors are made by rolling two metal foils with a strip of paper and then impregnating with a dielectric between them. For high voltage applications, several layers of papers are used to separate the metallic foils.

#### Mica capacitor

Mica is used as a dielectric between the metallic plates in this type of capacitors.

#### Ceramic capacitor

In this type of capacitor, ceramic is used as a dielectric which has a high dielectric constant. Ceramic capacitors have good stability with regards to temperature and voltage changes.

#### Polyester capacitor

In this type of capacitors polyester is used as a dielectric to impart a high breakdown voltage.

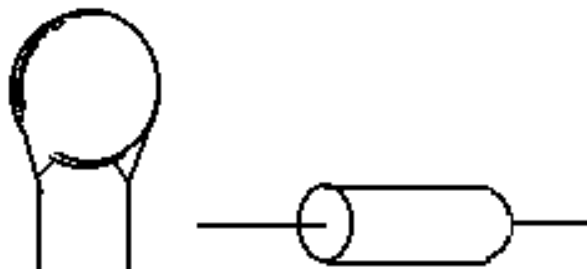

Disc Ceramic Tubular Ceramic

#### Electrolytic capacitor

An electrolytic capacitor consists of an aluminum-foil positive plate immersed in a solution called an electrolyte (ionizable solution capable of carrying current). The aluminum foil is the positive plate, and the electrolyte is the negative plate, if a liquid can be called a plate. To make an electrical connection to the liquid, another aluminum

foil is placed in the solution. To prevent the two foils from touching each other, a piece of gauze is placed between them. The +ve foil is surrounded by a thin oxidized film formed due to application of a particular voltage which acts as the dielectric. Electrolytic capacitors can not be used in AC circuits.

## Variable capacitors

Variable capacitors are widely used in radio frequency work where it is required to change the value of the capacitor in order to tune the circuit to a particular frequency. Usually, air is used as a dielectric in this type of capacitor. The capacitance is made to vary either by changing the distance between the plates or by changing the plate area exposed. This type of capacitor may consist of two plates or more than two plates. Metallic gang capacitors and button trimmers are the most common examples of variable capacitors. In a trimmer the two metallic plates are made to vary in their distance with the use of a screw.

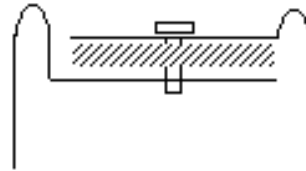

A trimmer

## Impedance

Impedance is the total opposition to current flow in an AC circuit. It takes into account all sources of opposition. Since it is the total opposition, impedance is measured in ohms, just as resistance and reactances are. If an inductor and resistance are connected in series with a source of A.C., the impedance of the circuit is:

$$Z = \sqrt{X_L^2 + R^2}$$

If  $X_L = 4$  Ohms and  $R = 3$  Ohms

Therefore,

$$Z = \sqrt{16 + 9}$$

= 5 Ohms

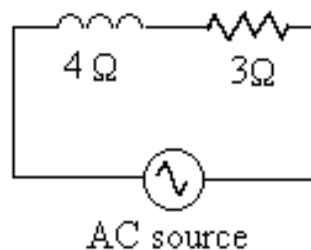

AC source

The impedance of a series R-L circuit can never be equal to or as great as the sum of  $X_L$  and  $R$ , nor can it be equal to or less than either  $X_L$  or  $R$ .

## Inductance and Capacitance in Series

When an inductor and a capacitor are connected end to end, a series L-C circuit is formed. If the inductor is a pure inductor and capacitor, a pure capacitor, then the circuit has no D.C. resistance which is practically impossible. There is always some resistance present in the circuit. Inductor has inductive reactance,  $X_L$  and



capacitor has the capacitive reactance,  $X_C$ . The net resistance present in the circuit is negligible.

If the circuit has an inductance  $L$  of 1 henry in series with a capacitor  $C$  of 10 MFd and the applied voltage  $E$  is 100 volts and frequency is 50 Hertz.

Then,

Inductive reactance  $X_L = 2\pi fL = 6.28 \times 50 \times 1 = 314$  Ohms

Capacitive reactance,

$$X_c = \frac{1}{2\pi fC} = \frac{1}{6.28 \times 50 \times 0.00001} = \frac{1}{0.00314} = 318.5 \Omega$$

The impedance of such circuit is the difference of inductive reactance and capacitive reactance.

$$Z = X_C - X_L = 318.5 - 314 = 4.5 \text{ Ohms}$$

If  $X_L$  is greater than  $X_C$  then the impedance is  $X_L - X_C$ .

### Resonant frequency

Resonant circuits make it possible to select one frequency from all others. For example, there are hundreds of radio stations that broadcast signals strong enough to be received by your radio receiver. The tuning circuit of the radio receiver accomplishes the task of discarding all other signals but to allow only the desired signal to be processed. The single frequency at which the circuit responds best is called the resonant frequency of the circuit. Resonance occurs when the inductive reactance becomes equal to capacitive reactance or  $X_L = X_C$ .

It can be achieved by either varying capacitance or inductance. In a radio receiver, it is achieved by varying the value of the variable capacitor. A series resonant circuit offers very little resistance when the circuit operates at the resonant frequency. High current is permitted to flow through the circuit.

### Parallel Resonant Circuit

In the circuit diagram shown below, the part of the circuit between the points 'a' and 'b' is called a 'tank' because the resonant frequency will be captured and held there while all other frequencies are allowed to flow through it. So if the AC source is producing AC current at the resonant frequency, that current is blocked by the tank. The current is not permitted to travel from 'a' to 'b' through the tank. But when the AC source is producing current at any other frequency, the current can flow from 'a' to 'b' with little opposition.

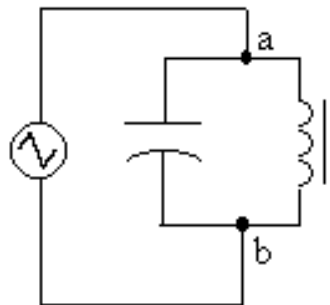

A parallel resonant tank circuit

### Tuning Circuit

In a radio receiver, the selection of the desired frequency out of hundreds of other frequencies is achieved by the use of resonant circuit. The resonant circuit basically consists of an inductor and a capacitor. The frequency of resonance is usually achieved by changing the capacitance of the variable capacitor.

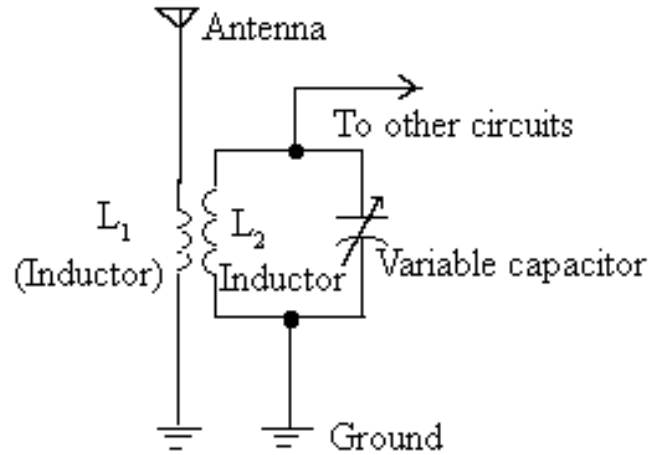

A radio tuning circuit

In the tuning circuit shown above, all the frequencies captured by the antenna are passed to ground through the primary coil  $L_1$ . They will try to cause current flow in the tank circuit, but only the resonant frequency will be successful in creating a current flow. The information it carries will be sent to the other radio circuits while the non-resonant frequencies are practically ignored.

In the circuit shown above, the condition of series resonance is present but is not apparent. In this circuit the transformer secondary coil has a capacitor across it with a reactance of the secondary, forming a resonant circuit. At first glance it appears to be a parallel-resonant circuit. The primary coil, however, is inducing an AC voltage into each turn of the secondary coil. Theoretically, the secondary may be considered to have a source of AC inserted in series with its turns.

### Filtering

Resonant circuits are used to filter out the desired frequency. A series resonant circuit allows to pass its resonant frequency while the parallel resonant circuit (called the tank circuit) blocks the flow of its resonant frequency

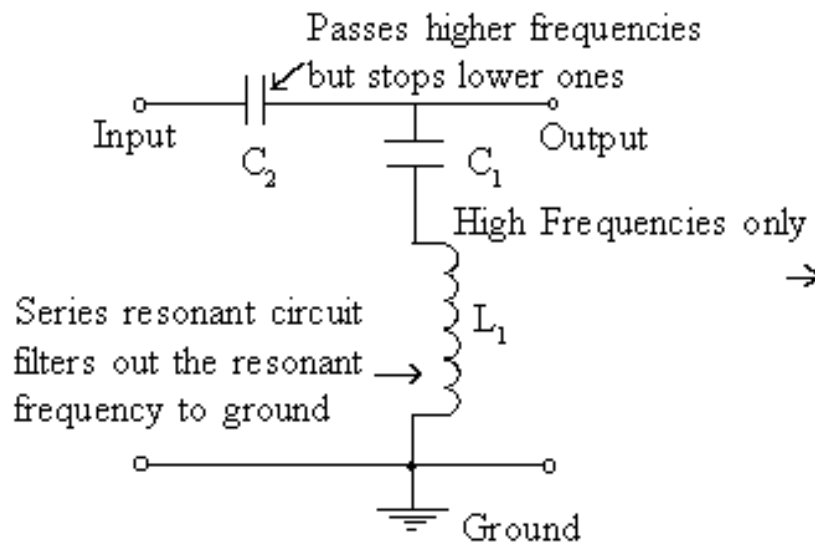

High pass filter

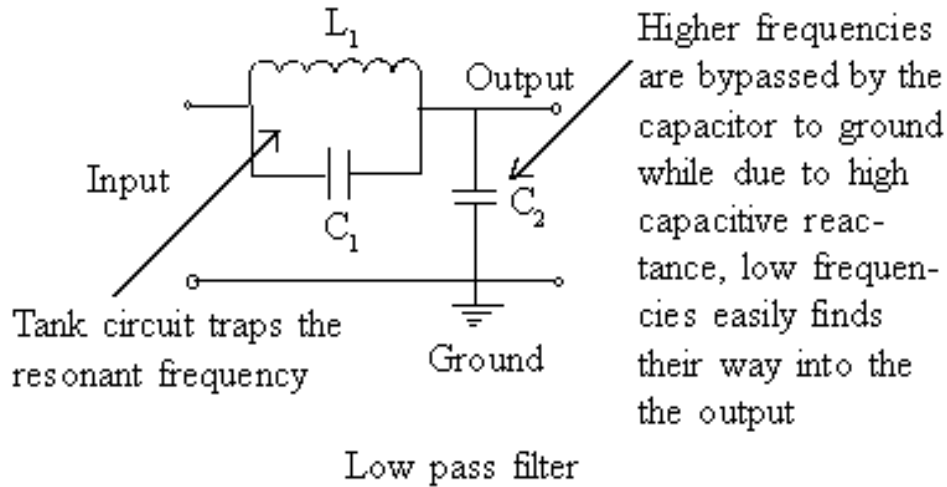

### ‘Q’ of a circuit

The term ‘Q’ is applied to AC circuits in which inductance and capacitance are involved. It in fact express the ‘quality’ of the inductor or capacitor and since lesser the ohmic resistance of the coil (inductor), more perfect inductor the coil is, with little loss. ‘Q’ can be found from the formula:

$Q = X_i / R$  (in case of coil); where  $X_i$  = inductive reactance,  $R$  = Ohmic resistance.

Again,  $X_i = 2\pi fL / R$ , where  $f$  = frequency,  $L$  = inductance

Therefore,  $Q = 2\pi fL / R$  ; this shown that the same coil or inductor possesses high ‘Q’ at higher frequency.

### Skin effect

A phenomenon called ‘Skin effect’ also causes a less efficient coil or inductor. It is observed that at higher frequencies, electrons flow nearer to the surface of the conducting wire; since the usable cross-sectional area lessens, the ohmic resistance increases resulting in a lower ‘Q’.

#### Prevention of ‘Skin effect’

- i. By using large diameter wire.
- ii. By silver-plating of the wire used.
- iii. Using fewer turns while making the coil, but increasing the core permeability; e.g. using powdered iron core.
- iv. By using ‘Litzendraht wire’, an insulated multistrand wire. Several thin strands have more surface for a given wire diameter than does a solid wire (Litz wire is effective only up to about 1 MHz)

## B. Thermionic Emission & Valves

An electric current can also flow in a gas. A voltage applied across a gas-filled tube causes ionization of the gas: free electrons stream towards the plate with the positive potential, colliding with the atoms in their way and detaching electrons from their orbits. The positive ions move toward the opposite end of the tube.

The most common material used in the construction of a vacuum tube envelope is glass. The electrode leads pass

through a glass bead sealed into an eyelet. The electrodes in a vacuum tube are supported by insulators such as mica and a variety of ceramics. The electrodes themselves are commonly made from metals such as nickel, copper, aluminum, molybdenum, and tungsten.

In thermionic valves the electrons move in a vacuum. An example of such a device is the diode. The envelope of a diode houses two main parts which are also called the anode and the cathode. Near the cathode there is a filament or miniature electric heater which heats the cathode. Most tubes employ heater-cathodes. A heater cathode consists of a metal cylinder coated with special oxides that liberate great quantities of electrons when heated to a relatively low temperature. In this case an "electron liquid", consisting of electrons that move chaotically the very body of the cathode, between its atoms, begin to "boil". This phenomenon is known as 'electronic emission'. As a result of this emission, a cloud of "electron gas" is formed round the cathode. If the cathode is now connected to the negative terminal of a voltage source and the anode, to the positive terminal, the anode will begin attracting electrons from the cloud, "drawing" them away from the cathode, and a current will flow inside the diode. Freedom for the electron proves very short-lived: no sooner does it escape from the cathode than it is immediately attracted by the anode.

A diode is in fact a one-way valve. When the negative terminal of the voltage source is connected to the anode and the positive terminal to the cathode, the electrons will not be able to escape the cathode, because it attracts them. But even those that do escape have nowhere to fly in particular: previously they were attracted by the anode, now it forces them back to the cathode. With such a connection no current flows through the diode (this property of the diode is employed for converting the alternating current to direct current which is called rectification)The current flowing through a diode is called the plate (anode is also known as plate) current. The flow of plate current can be controlled by two ways: by varying cathode temperature; and by changing the amount of voltage applied (called the plate voltage). But cathodes are designed to operate most efficiently at one particular temperature. An increase in plate voltage results in an increase in plate current. But after a certain point, further increase in plate voltage will not cause any more increase in the plate current. This point is called the saturation point.

### **Diode valve as a rectifier**

As shown in the circuit given below, the source of plate voltage in the plate circuit is a transformer providing an alternating voltage to the plate. During one half cycle the plate end of the transformer-secondary winding may be positive and the cathode end negative. On the next half cycle the plate end will be negative and the cathode end positive. As described above, the diode allows only one half cycle of the emf to produce current in the circuit. With ac plate voltage the plate current is pulsating dc. This one-way-gate effect is a main use of diodes. A diode is also called a rectifier.

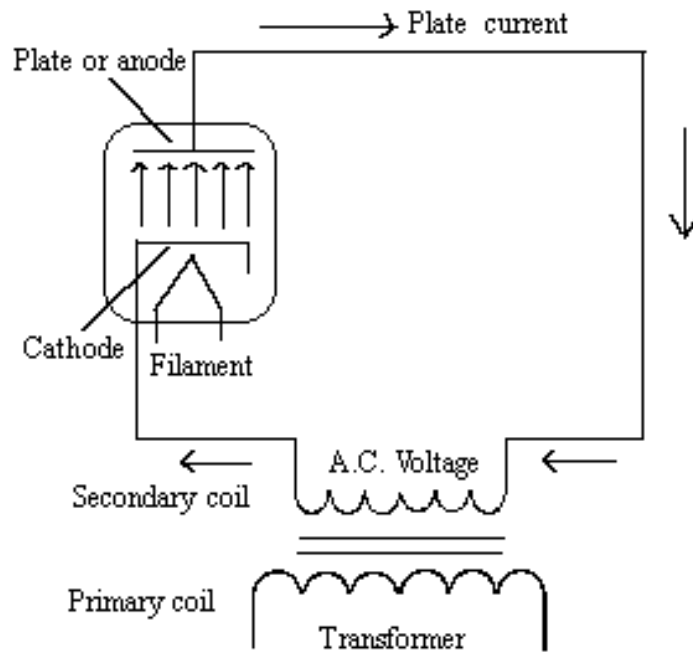

## Triode Valve

The introduction of a third electrode (control grid) between the cathode and the anode of a diode makes it a triode. In the triode, current is controlled by means of a voltage applied between the cathode and the grid. With a high negative grid potential (with respect to the cathode), the grid becomes a barrier for the electrons. They will "crowd" in the space between the cathode and the grid; the valve will be cut off, since no current will flow from the cathode to the anode. With a positive grid potential, the grid will help the anode, since its positive potential will be added to that of the anode. A heavy current will flow through the valve. However, with too high a positive grid potential the grid may turn from a helper of the anode into its competitor: some electrons will be drawn to it and will not reach the anode. In this case a harmful grid current appears in the valve. That is why in normal operation the grid is made to vary only more or less negatively.

## Amplification factor of a triode valve

In the circuit shown below, the voltage ( $-E_g$ ) in the grid circuit is  $-8$  V. Plate voltage is  $200$  V. Plate current is  $3$  mA. By increasing  $E_p$  by  $40$  V it is found that plate current increases from  $3$  to  $7$  mA. Returning to the original values, Grid voltage ( $-E_g$ ) is  $-8$  V,  $E_p=200$  V, and  $I_p=3$  mA, it is found that if the  $-E_g$  value is reduced by  $2$  V, from  $-8$  to  $-6$  V, the  $I_p$  will again rise from  $3$  to  $7$  mA. This indicates that the same  $I_p$  change can be produced either by changing the  $E_p$  by  $40$  V or by changing the  $-E_g$  by  $2$  V. This controlling ratio of  $40:2$  is equal to  $20$ . The tube is said to have a  $\mu$  (mu) or amplification factor of  $20$ . Thus the grid is found to be  $20$  times more effective in changing plate current than the plate voltage is.

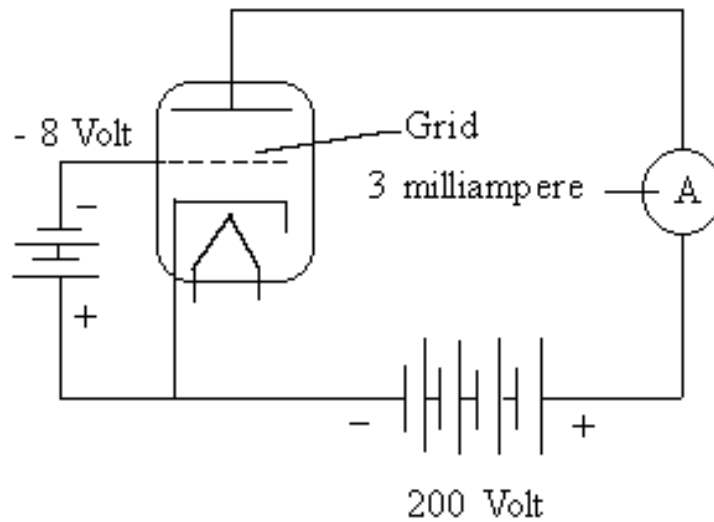

### Triode as an amplifier

In a theoretical circuit comprising a microphone, a transformer, a triode valve with a load resistance, the microphone induces a small ac voltage into the secondary of the transformer and between grid and cathode. With no signal applied to the grid and with 100 V from the plate supply, the dc voltage-drop across the load resistor  $R_L$  might be 75 V. As the input signal reaches a peak of 1V negative, the current in the plate circuit will decrease. The voltage drop across the plate-load resistor might decrease by 12 V, to 63 V across the  $R_L$ . As the grid voltage swings to 1 V positive, the plate current will increase, until there is a voltage drop of perhaps 87 V across the load resistor. As grid voltage varies from  $-1$  V to  $+1$  V (a 2 V peak to peak variation), the voltage across the load resistor varies between 87 and 63, i.e. 24 V. The voltage ratio of 2:24 indicates that across the plate load resistor, the voltage variation is 12 times more than the variation between the grid and the cathode.

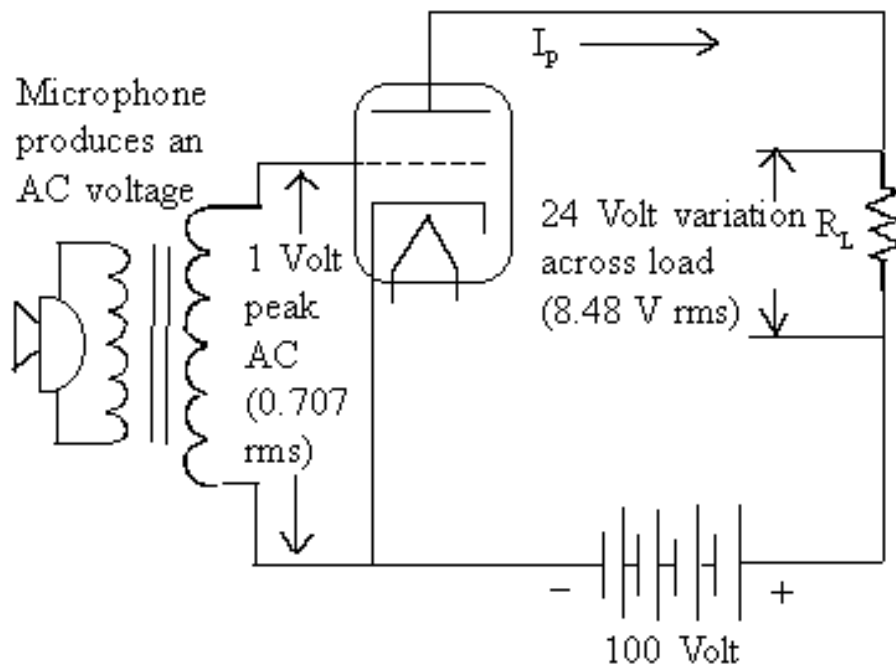

### Bias voltage

In the circuit described above, the grid was driven negative and positive alternately. But this creates distortion. To avoid the distortion, in a practical circuit, the grid may never be allowed to become positive and thus there is no grid current ( $I_g$ ) from the cathode. This is accomplished by adding a dc voltage source in series with the grid-cathode circuit. The negative potential is applied to the grid through the transformer, and the positive

potential to the cathode. The negative dc voltage added in series with the grid circuit is known as the bias voltage. If a negative 10 V bias is enough to produce plate-current cutoff with a given plate voltage, then a possible bias voltage would be half of this, i.e. 5 V for a class A amplifier. It can accommodate a peak ac emf of 5 V from the secondary of the grid-circuit transformer and neither cutoff the plate current nor drive the grid into positive region.

## C. Semiconductors: Diodes & Transistors

In the early days of electricity there were only two groups of material: insulators and conductors. Insulators are matters, which do not allow the flow of electric current through them. Glass, porcelain, dry air and dry wood are well known insulators. Metals are known to be good conductors, with copper and silver among the best. The conductivity of a particular material depends on the number of free electrons present in it.

There is another group of material known as semiconductors. Semiconductors like germanium and silicon are bad conductors of electricity in their purest form. But when certain impurities (indium or arsenic, which have a slightly different atomic structure from that of germanium or silicon) are added in the form of carefully controlled quantities, either an increase of free electrons or deficiency of electrons results. A semiconductor is called an **n-type semiconductor** where conduction takes place by reason of excess free electrons. A semiconductor is called a **p-type semiconductor** where conduction takes place due to freely moving 'holes' (positively charged) which replace electrons displaced by random electron movement in the material.

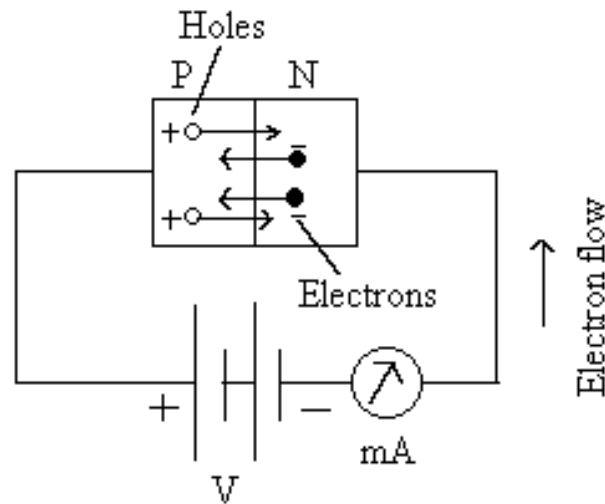

P-N Junction diode with Forward Bias

When pieces of p-type and n-type semiconductors are joined together, a p-n junction results. Flow of electric current through such a junction is possible only when the positive pole of the battery (voltage source) is connected to the p-type semiconductor and the negative pole to the n-type semiconductor. This is called the **"forward biased"** condition. In this condition, positively charged holes are repelled by the battery voltage towards the junction between p and n type material. Simultaneously, the electrons in the n-type material are repelled by the negative battery voltage toward the p-n junction. Despite the presence of a potential barrier at the p-n junction, which prevents electrons and holes from moving across and combining, under the influence of the electric field of the battery the holes move to the right across the junction and the electrons move to the left. As a result, electrons and holes combine and for each combination of that takes place near the junction, a covalent bond near the positive battery terminal breaks down, an electron is liberated and enters the positive terminal. This action creates a new hole which moves to the right toward the p-n junction. At the opposite end, in the N-region near the negative terminal, more electrons arrive from the negative battery terminal and enter the n-region to

replace the electrons lost by combination with holes near the junction. These electrons move toward the junction at the left, where they again combine with new holes arriving there. As a consequence, a relatively large current flows through the junction. The current through the external connecting wires and battery is due to that of the flow of electrons. If, however, the polarity of the battery is reversed, i.e., the positive terminal is connected to n-type semiconductor and the negative terminal of the battery to the p-type semiconductor, the p-n junction will block the electron flow by building up a voltage barrier at the junction. The holes are now attracted to the negative battery terminal and move away from the junction because of the attraction of the positive terminal. Since there are effectively no hole and electron carriers in the vicinity of the junction, current flow stops almost completely. This type of device is called a "solid state diode" or a semiconductor. By exploiting their property of one way flow of electric current, they can be utilized to convert alternating current to direct current (known as rectification). Without adequate filtering, the resultant d.c. is pulsating in nature.

## Transistors

The simplest of the transistors are of two types-either p-n-p or n-p-n. Two p-n junction diodes can be sandwiched back to back to form a p-n-p or n-p-n junction transistor. But in a practical transistor, the center or n-type portion of the sandwich is extremely thin in comparison to the p-regions. In the 1<sup>st</sup> illustration, **both the p-n junctions are reverse biased.**

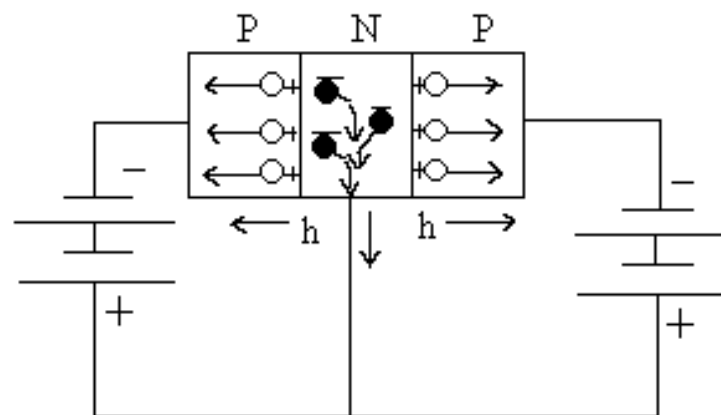

Non-Conducting P-N-P Junction

In this type of connection, holes in the each of p-region are attracted towards the negative battery terminal and the mobile electrons in the n-region are initially moved away from both junctions in the direction of the positive battery terminal. Due to the displacement of holes and electrons, there will be no current flow in the external circuit.

In the 2<sup>nd</sup> illustration, one of the p-n junctions is forward biased, while the other is reversed biased. In a transistor, the middle layer (here n-region) is called the **base**, the forward biased p-n junction is called the **emitter** junction and the reverse biased p-n junction is called **collector** junction. Due to the positive potential at the emitter junction, the holes in the p-region cross into the n-region (**the base**). But this region is very thin and there are very few electrons with which holes can combine. So, majority of the holes drift across the base into the collector junction. About 5 per cent of them are lost in the base region as they combine with electrons. For each hole that is lost by combination with an electron in the base and collector areas, a covalent bond near the emitter electrode breaks down and a liberated electron leaves the emitter electrode and enters the positive battery terminal. The new hole that is formed then moves immediately toward the emitter junction, and the process is repeated. Thus, a continuous supply of holes are injected into the emitter junction, which flow across the base region and collector junction, where they are gathered up by the negative collector voltage. The flow of current within the p-n-p transistor thus takes place by hole conduction from emitter to collector, while conduction in the external circuit is due to the conduction of electrons.



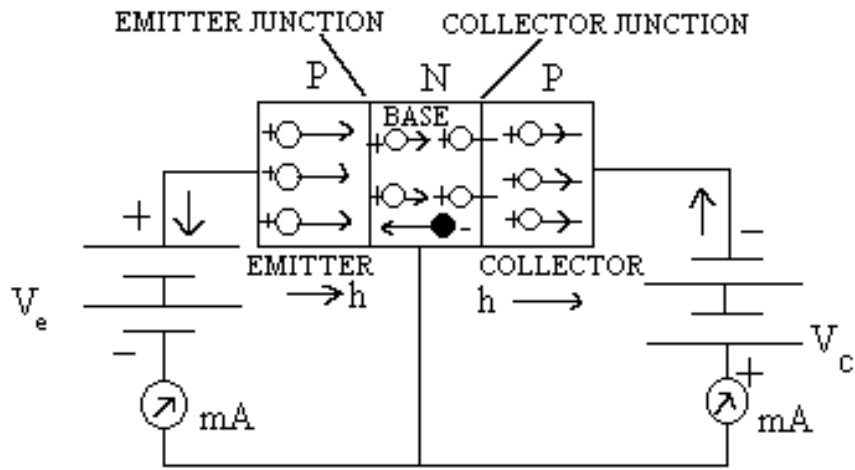

Basic connection of P-N-P Junction transistor

Because of the reverse bias no current can flow in the collector circuit, unless current is introduced into the emitter. Since a small emitter voltage of about 0.1 to 0.5 volt permits the flow of an appreciable emitter current, the input power to the emitter circuit is quite small. As we have seen, the collector current due to the diffusion of holes is almost as large as the emitter current. Moreover, the collector voltage can be as high as 45 volts, thus permitting relatively large output powers. A large amount of power in the collector circuit may be controlled by a small amount of power in the emitter circuit. The power gain in a transistor (power out/power in) thus may be quite high, reaching values in the order of 1000.

**The ratio of collector current to emitter current is known as alpha ( $\alpha$ ) and it is the measure of possible current amplification in a transistor.  $\alpha$  cannot be higher than 1.**

### Transistor Symbols and Connection:

When transistors are operated as amplifier, three different basic circuit connections are possible: (a) Common-base, emitter input; (b) common-emitter, base input; and (c) common-collector, base-input.

Regardless of the circuit connection **the emitter is always forward biased and collector is always reverse biased.**

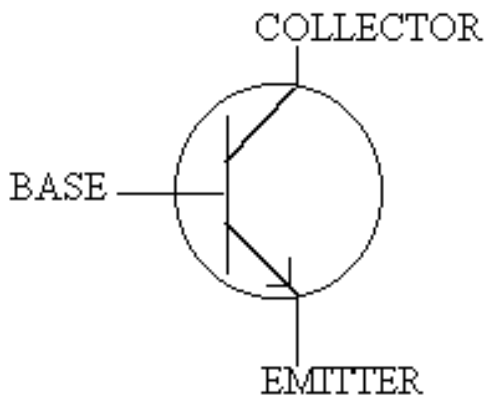

Circuit symbol of a NPN transistor

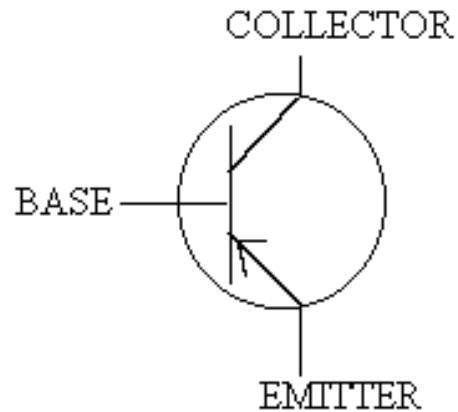

Circuit symbol of a PNP transistor

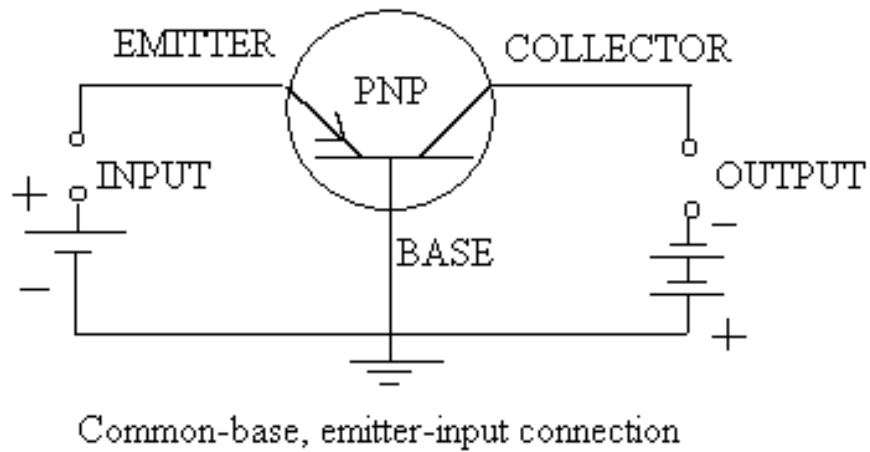

## D. Radio Receivers

**Q. Compare and contrast a Tuned Radio Frequency (TRF) receiver with a Superheterodyne receiver.**

A **TRF receiver** consists of the following stages:

- i. Antenna input stage
- ii. A few stages for RF-amplification
- iii. A detector stage for demodulation
- iv. One or more stages of AF amplifier

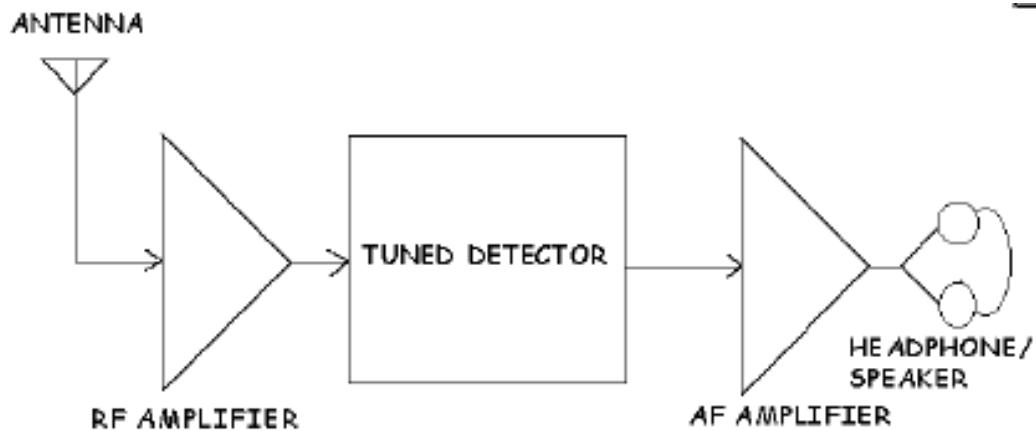

BLOCK DIAGRAM OF A SIMPLE TUNED RADIO FREQUENCY RECEIVER

On the contrary, a **superhet receiver** consists of :

- i. RF Amplifier
- ii. Mixer or Converter
- iii. Local Oscillator
- iv. IF Amplifier
- v. Detector

vi. Automatic Gain Control (AGC) Circuit.

vii. AF Amplifiers

1. In a TRF receiver a series of loosely coupled tuned circuits are used to increase selectivity and each circuit are ganged so that they resonate at the same frequency. But in a superhet receiver, this principle is not followed, instead, the RF amplifier, mixer and local oscillator are ganged to produce an intermediate frequency.
2. In a TRF receiver the high amplitude original frequency is demodulated at the detector stage. But in Superhet sets, the IF is demodulated.
3. In a TRF Receiver, no image frequency is produced. But image frequency is produced in superhet receiver.
4. In a TRF receiver, selectivity is not constant; the receiver is more selective at the low frequency bands, while less selective at the high frequency end. Because the detector and amplifiers of a superheterodyne receiver can be designed to amplify only intermediate frequency (IF), this type of receiver is more selective and offer high fidelity (exact reproduction quality of the transmitted signal).
5. In TRF receiver, amplification is not constant over the tuning range. In superhet receiver amplification standard is constant since all the time it amplifies a constant frequency at the IF stages.

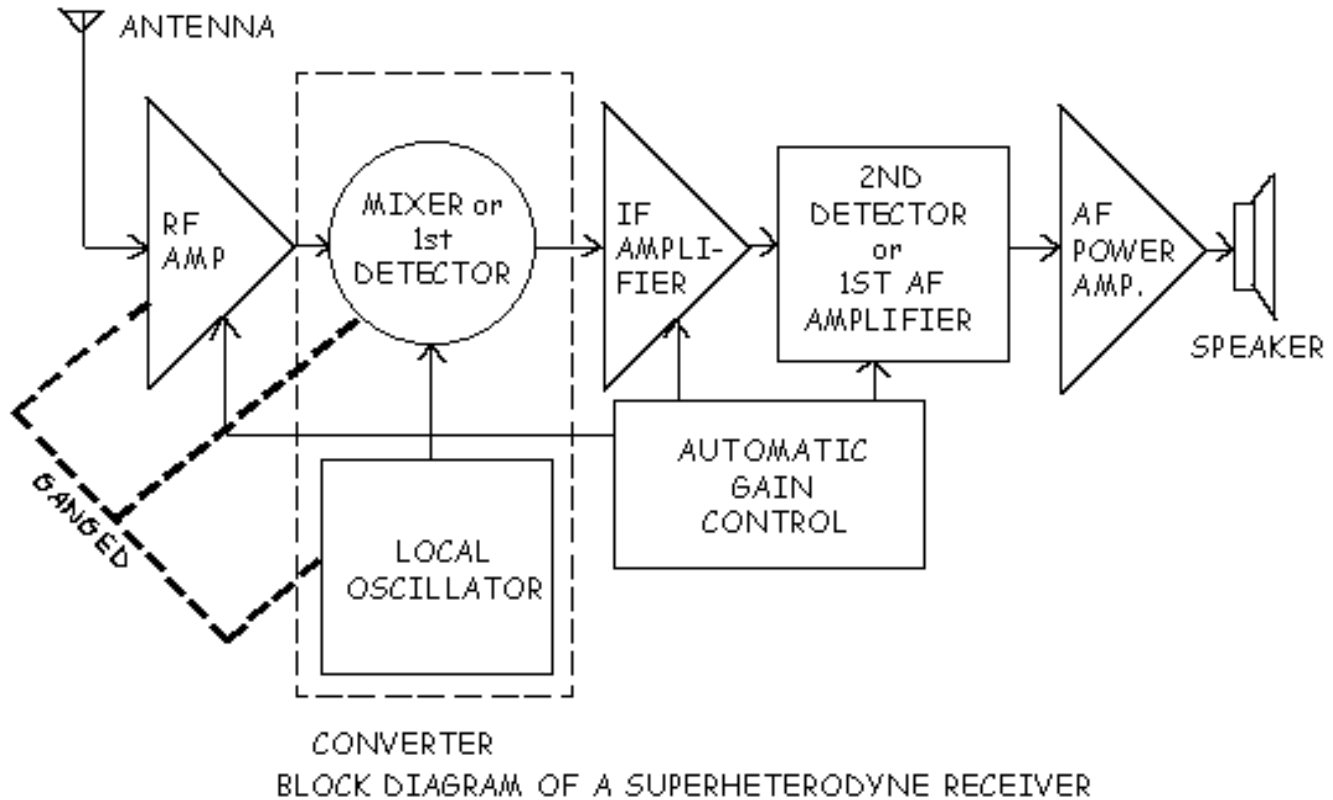

**Q. How the RF amplifier, Local Oscillator and mixer circuit of a superhet receiver maintains a constant frequency separation and why?**

The main objective of the superheterodyne receiver is to produce an intermediate frequency (IF) by the process of heterodyning or beating.

This can be accomplished when two frequencies are mixed to produce the beat frequency. In superhets, the IF is usually 455 kHz which is selected because the broadcast band begins above that frequency. So, if we imagine a situation when the RF amplifier is tuned to receive a 800 kHz broadcast signal, the local oscillator must be tuned to 1255 kHz which will result in an IF of 455 kHz ( $1255 - 800 \text{ kHz} = 455 \text{ kHz}$ ).

Since we have to tune the RF amplifier section throughout the entire broadcast band, the frequency of the local oscillator must also vary in a manner that it always maintains a gap of 455 kHz. To achieve this condition, the Local Oscillator and RF Amplifier section are 'ganged', i.e. their tuning condensers are connected/ganged mechanically in such a way that when we tune the variable capacitor in the RF section, the variable capacitor in the local oscillator also changes its value, it 'tracks' the frequency to which the 'Aerial Circuit' is tuned and remain separated from the tuned frequency by 455 kHz up.

The Intermediate Frequency (IF), which is a considerably low frequency is being used, because-

- i. it is a suitable frequency to achieve amplifying efficiency.
- ii. It provides better selectivity.
- iii. It provides better sensitivity throughout the broadcast band.
- iv. It provides uniform sensitivity as well as uniform selectivity.

### **Q. Write a short note on 'Selectivity'.**

Selectivity is the measure of the ability of a radio receiver to select a particular frequency or particular band of frequencies and rejecting all other unwanted frequencies. But higher selectivity does not necessarily make a better receiver. For instance, a 'broadcast signal' consists of the carrier frequency and its two side bands. In a situation where a carrier frequency of 800 kHz is modulated with a 5 kHz (5000 Hz) tone, the sum of the carrier and the audio frequency results in the Upper Side Band (USB) of 805 kHz. The difference of carrier and audio frequency results in a Lower Side Band (LSB) of 795 kHz. So, for proper reproduction of the broadcast signal at a particular carrier frequency, the receiver must receive (select frequencies from 795 to 805 kHz. A receiver more selective than this would reject a part of the frequencies thus proper reproduction would be hindered.

### **Q. Explain the function of each stage a super-heterodyne receiver of briefly.**

#### **Radio Frequency (RF) Amplifier section**

This section performs two major tasks:

- i. it couples the antenna voltage to the converter of the receiver;
- ii. By selectivity, it accepts only the desired frequency and all others are rejected.
- iii. By amplifying the desired signal, the Signal-to-Noise ratio is increased in the converter stage for efficient operation.

#### **Converter or Mixer Section**

The main objective of the superheterodyne receiver is to produce a constant Intermediate Frequency (most commonly used frequency being 455 kHz in commercial broadcast band radio sets) which is suitable for-

- i. gaining efficiency of the electronic circuit so far as its amplification is concerned;
- ii. providing uniform Selectivity;
- iii. providing uniform sensitivity;

So a Local Oscillator and a Mixer circuit are combined, where, by the process of 'heterodyning', i.e. 'beating', the 'Intermediate Frequency (IF)' is obtained.

If the RF Amplifier section selects and amplifies a signal of 800 kHz, then the local oscillator produces a frequency of 1255 kHz. By mixing both the frequency at the mixer stage, a difference of frequency of the value 455 kHz is obtained ( $1255-800=455$  kHz)

### **Intermediate Frequency (IF) Amplifier**

The 455 kHz IF is fed to the IF amplifier through an IF transformer. The circuitry of the IF section is so designed and tuned so that it gives the optimum gain at that particular IF frequency.

### **Detector/Demodulator and 1<sup>st</sup> Audio Frequency Amplifier stage**

The Amplitude Modulated (AM) IF is demodulated and detected. A diode working as rectifier solves this purpose. The triode/transistor amplifies the audio signal and the volume control potentiometer system controls the intensity of sound.

### **AF Power Amplifier**

This section further amplifies the audio signals which is finally fed to an output transformer which matches the impedance of output stage with the speaker (in modern transistor receivers, the necessity of output transformer is eliminated).

### **Q. Write a note on AGC or AVC in a superhet radio set.**

Automatic Gain Control is a most needed part of superhet circuitry. A disadvantage of manual gain control (volume control) with a receiver is that it can't provide constant output under all conditions. If a receiver is tuned from a weak signal to strong signal, its output must increase intolerably. This would then require readjustment of the volume control. Similarly, when a receiver is tuned to particular signal the output level can vary widely if the input signal strength fluctuates as a result of fading and adjustments of the volume control has to be done. Since such signal fluctuations are rapid, constant readjustment of volume control would be necessary which is impractical. This is where AGC or AVC comes into picture and is used in addition to the manual control.

All AGC or AVC (Automatic Volume Control) circuits perform two basic functions;

- i. The first of these is to develop a DC (Direct Current) which is proportional to the receiver input signal all the time.
- ii. The AGC voltage is applied to the RF and IF stage of the receiver where it serves as a Bias voltage.

In this way the AGC voltage controls the gain of RF and IF stages, and therefore the overall gain of the receiver. When the signal level at the receiver input increases, the AGC voltage increases proportionately. Consequently, a larger bias is applied to the IF and RF stages and their gain is applied to the IF and RF stages and their gain is reduced.

The receiver output thus remains relatively constant instead of increasing in accordance with the input signal strength and vice-versa.

In valve type RX (receiver), the grids of RF and IF portions valves are biased by negative voltage. While in a transistor it depends on transistor type.

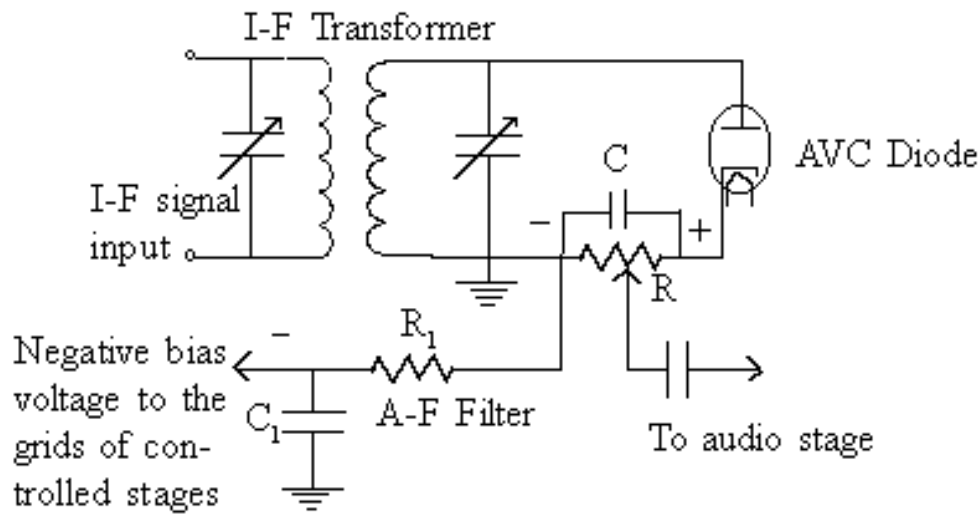

An Automatic Volume Control (AVC) Circuit

### Q. What is a squelch circuit ?

The squelch circuit or Q (Quieting) circuit is a circuit which is controlled by AGC or AVC voltage. The modern high gain receivers show a disadvantage without it, that is, without a squelch circuit, annoying buzzing and cracking sounds are heard over the loudspeaker in absence of input signal. So a circuitry is arranged in such a way that AF gain is kept reduced in absence of input signal from the antenna.

With no signal there is no Negative AGC voltage, and the squelch tube allows current to flow through it then passing through R3 to the +250 V point. Thus R3 produces a DC voltage drop across it which is more negative at midpoint than at the bottom being in series with the amplifier grid circuit, tube past cutoff, preventing it from functioning.

When a signal is received, AGC or AVC voltage biases the squelch tube to 'cutoff', stopping plate current flow. Consequently, the voltage drop across R3 ceases, allowing the AF amplifier tube to act in a normal manner.

### Q. Write a note on Image Frequency in a superheterodyne receiver set.

The intermediate stage (mixer + local oscillator) of a superhet radio set produces an Intermediate Frequency (IF) due to the beating of RF input frequency and Local Oscillator Frequency. This frequency is obtained by deducting the **RF input from the tuned circuit** from that of **Local Oscillator Frequency**. So, while receiving a 800 kHz RF signal, the Local Oscillator is made to oscillate at a frequency of 1255 kHz which results in an Intermediate Frequency (IF) of 455 kHz (which is accepted as a standard in almost all the Broadcast band receiver circuits); but it is found that in case of comparatively less selective receiver, if a broadcast frequency 455 kHz up, from the 1255 kHz local oscillator frequency manages to intrude the RF tuned circuit even to a little extent, then another difference of frequency equal to intermediate frequency results; viz.  $1710 - 1255 = 455$  kHz. But this '455 kHz' being generated from a signal frequency having different audio information causes adverse effect at the audio end of the receiver. The intelligence of both would be present in the speaker at the same time making the sound reproduction is unintelligible.

### Prevention of Image Frequency

- i. By highly selective RF tuned amplifier;
- ii. By using an IF which is convenient to use and at the same time separation between desired and image signals is made large. Possibility of image frequency generation is greater in a receiver designed for an IF

of 175 kHz than a receiver using an IF of 455 kHz.

### Q. What is a S-meter?

A S-meter is a visual indicator of signal strength. A simple S meter consists of a milliammeter in series with an RF or IF amplifier plate/collector circuit.

With no signal, there is no AGC bias voltage and maximum plate current flows.

With a signal, the AGC biases the tube, reducing the plate current and the indication on the meter. The stronger the signal, the less current the meter indicator signifying a strong strength.

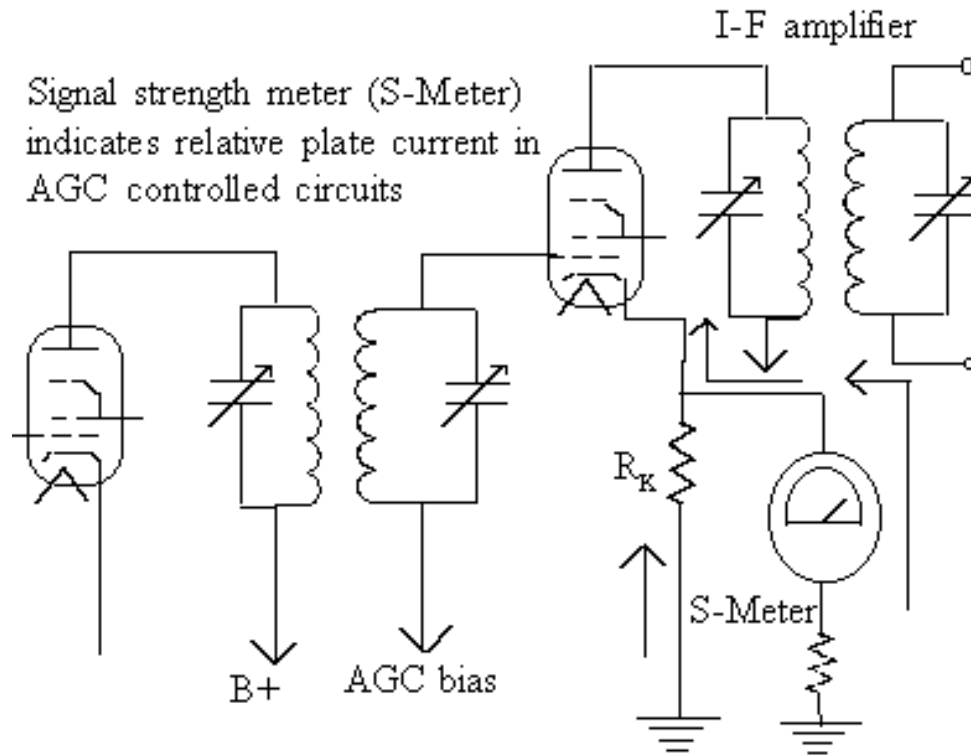

A typical S-meter circuit

### Q. What is a Beat Frequency Oscillator?

To change the second detector from a rectifying or envelope detector to a heterodyne detector to receive A1A (Continuous Wave Morse Code), A2A (Modulated CW Morse Code), J3E (Single Side Band), the Beat Frequency Oscillator is turned on. It is a variable frequency oscillator using a Hartley, Colpitts or Armstrong circuit. It is tunable to the Intermediate Frequency and one or two kilohertz higher and lower. It heterodynes with any signal coming through the IF strip, producing an audible beat frequency in the detector. Both the BFO and LO (Local Oscillator) must have good frequency stability.

### Q. Why ham radio transmissions are not heard in ordinary radio receiver sets? Can you receive ham radio transmissions in your ordinary radio set?

The radio sets available in the market for general public are designed to receive Amplitude Modulated (AM) or Frequency Modulated (FM) broadcasts only. But the ham radio operators use a very efficient mode of transmission called Single Side Band (SSB) transmission. The power of a ham radio station is also very low (

usually not more than 100 watts) in comparison to the broadcast station (which use power in the kilowatts range). In fact many of the broadcast band radio receivers available in the market also covers some of the frequencies which are allotted to the ham radio stations. A 4 band radio set (inclusive of the Medium Wave band) can be expected to cover some popular ham radio frequencies like 7 to 7.1 MHz (i.e. 7000 to 7100 kHz), 14 to 14.350 MHz (i.e. 14,000 to 14,350 kHz) and 21 to 21.450 MHz (i.e. 21,000 to 21,450 kHz). This kind of receiver can be improvised to receive ham radio transmissions with very little effort.

First, we will need an outdoor aerial. Because, these radio sets are not sensitive to receive low power transmissions. Majority of the hams use power below 100 watts (a broadcast station may use 4000 or 5000 watts of power!). A novice ham radio operator may be found to be operating with a power as low as 0.5 watt!

Ham radio conversation if heard on an ordinary radio set sounds like the 'Duck quacking'. There is no intelligibility in the audio. As already mentioned, our ordinary radio sets are meant to receive AM signals only and not to receive SSB signals-a separate unit is required at the '**Detector**' stage of the AM receiver, which is nothing but a stable '**Frequency Generator**' (RF Oscillator), called the '**Beat Frequency Oscillator**' (**BFO**). The BFO is used to introduce a '**Local Carrier Frequency**' (frequency of the carrier is 10 to 20 Hertz within that of the transmitter carrier frequency which is suppressed at the transmitter of the ham radio station willingly in order to save power).

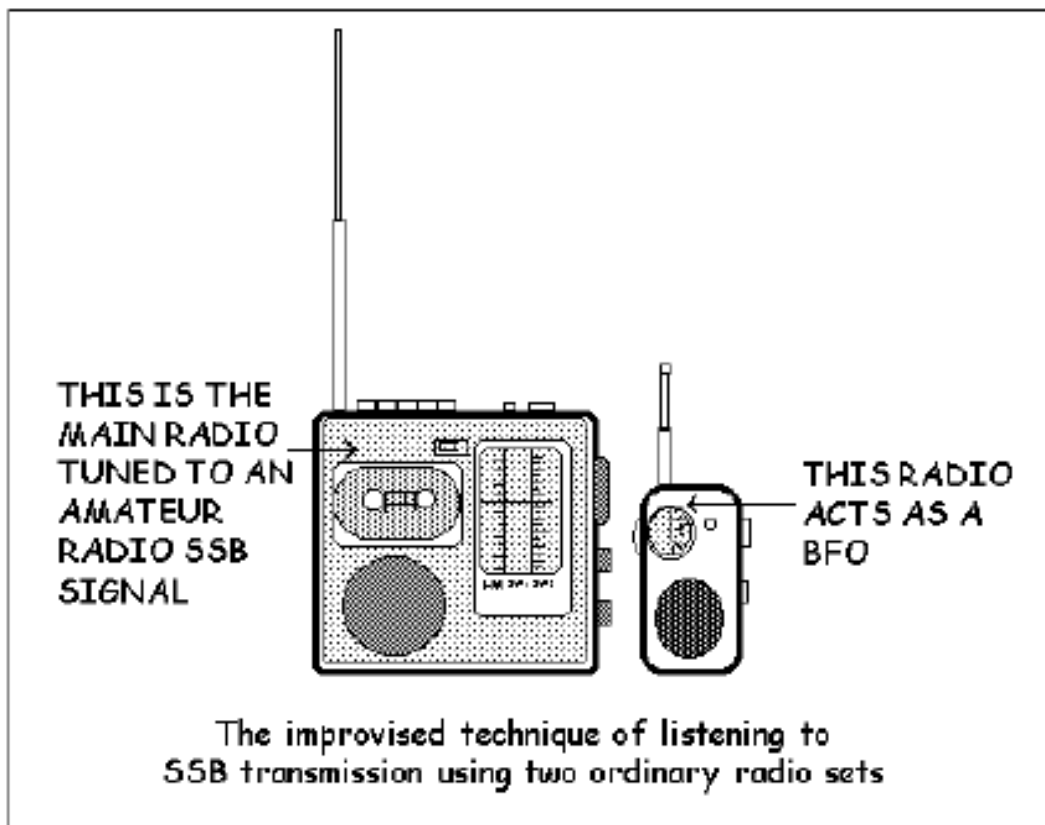

Another popular technique of receiving ham radio stations on an ordinary receiver set is to employ two radio sets. In this improvised technique, one radio set acts as the BFO. The radio sets are just kept very close together. The volume control knob of the radio set which we intend to use as a BFO should be kept at its minimum. Usually a two band (one Medium Wave and one Short wave) AM pocket receiver can be suitably used as a BFO. The first step is to locate a ham radio transmission over the main radio receiver (search for the "duck quacking" like audio) tuned to a ham frequency (say in the 40m or 20m band, i.e. 7-7.1 MHz or 14 to 14.350 MHz respectively). Once a strong ham station has been detected, the next step is to bring the pocket receiver (whose volume is kept at minimum) near to the main receiver. The pocket radio set should also be tuned to a frequency near to the frequency in which the ham transmission is received. By this way, frequency generated by the local



oscillator of the pocket radio can be made to produce the heterodyne effect in the main receiver making the ham transmission intelligible. This technique of course requires your patience. The first attempt should not become the last attempt!

## E. Radio Transmitters

### Q. Write what you know about Amplitude Modulation and %ge of modulation.

Amplitude Modulation (AM) is a process in which the amplitude of a radio frequency current is made to vary and modify by impressing an audio frequency current on it.

A radio frequency current has a constant amplitude in absence of modulation and this constant amplitude RF carries no information, i.e. no audio intelligence and is of no use to radio telephone (voice communication), but has application in morse code communication.

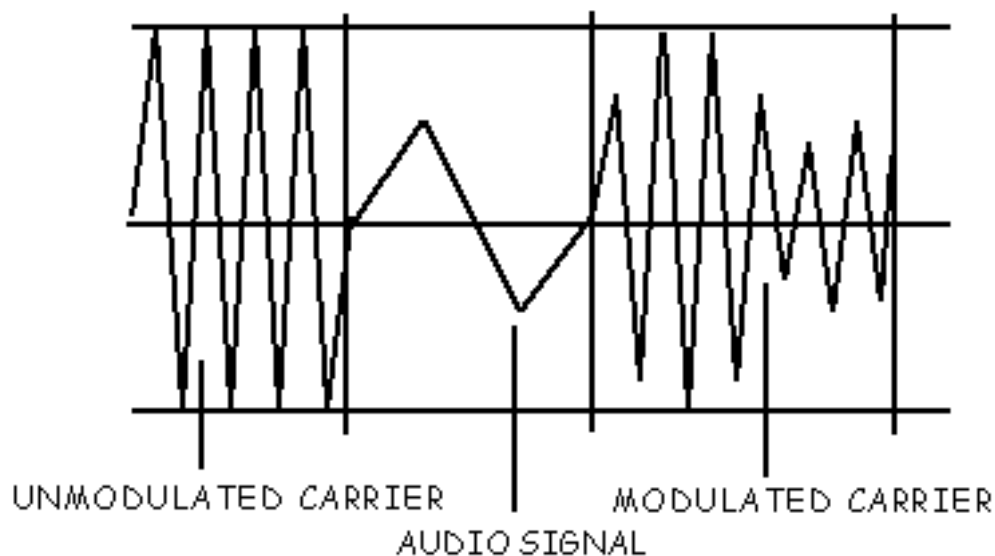

So, to give intelligence to the RF current, audio signal is impressed/superimposed on the RF current in a non-linear modulator circuit; as a result of which carrier current amplitude begins to rise to a maximum value above and below its original amplitude during the positive cycle of the audio signal and during the negative cycle of the audio signal, it falls to a minimum value.

This results in the carrier having two outlines of the audio signal, this is because the variation at instant in the amplitude of the carrier wave is directly proportional to the value of the modulating signal.

During amplitude modulation, two side band frequencies are also produced. Upper sideband frequencies equal to the carrier frequency plus audio frequency and lower side band frequency is equal to carrier frequency minus audio frequency. So the amplitude modulated carrier occupies a space in frequency spectrum, the width of which is equal to twice the highest modulating frequency.

### Percentage of modulation

The degree of modulation in an AM wave is expressed by %ge of maximum deviation from the normal amplitude of the carrier RF wave.

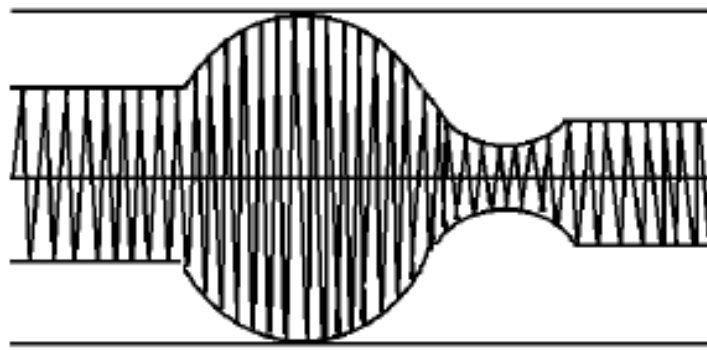

50% modulation

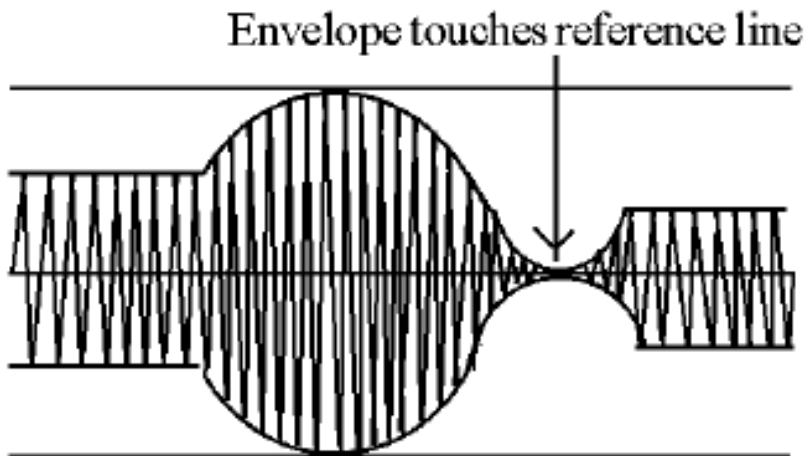

100 % modulation

The effect of such modulated wave is measured by a receiver's ability to reproduce the signal in distorted or undistorted manner.

$$\text{Percentage of modulation} = \frac{\text{Voltage}_{\text{Max}} - \text{Voltage}_{\text{Min}}}{\text{Voltage}_{\text{Max}} + \text{Voltage}_{\text{Min}}} \times 100$$

Where  $\text{Voltage}_{\text{Max}}$  is the maximum instantaneous value of the modulation and  $\text{Voltage}_{\text{Min}}$  is the minimum value of the RF carrier.

### Q. Why over modulation is not desirable?

Over modulation is not desirable, i.e. modulation should not exceed 100 %, because if modulation exceeds 100 % there is an interval during the audio cycle when the RF carrier is removed completely from the air thus producing distortion in the transmission.

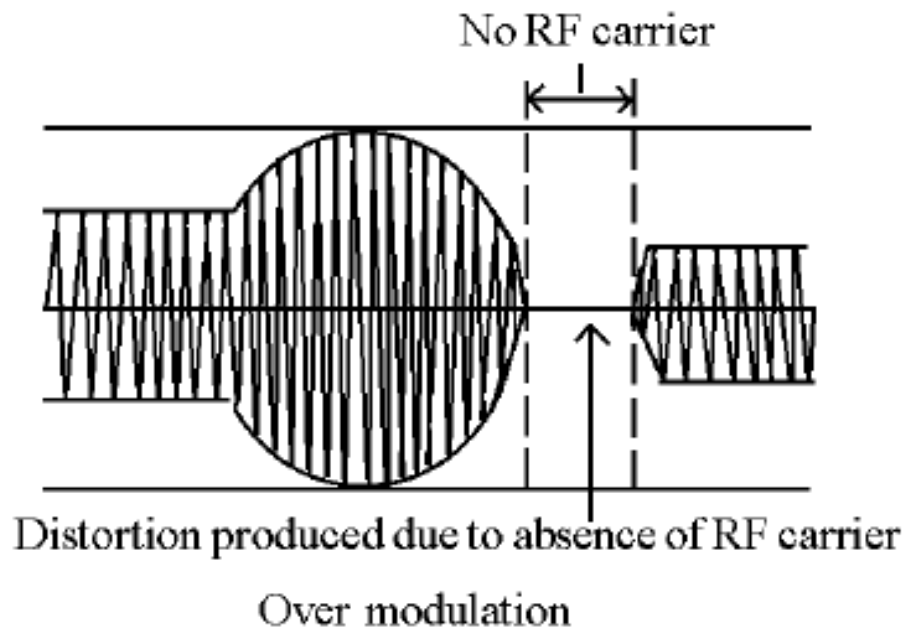

### Q. What are the Side-bands?

Side bands are the sum and difference frequencies produced at the transmitter by the modulating frequencies. For instance a 5 kHz (5,000 Hz) Audio tone might be used to modulate an 800 kHz carrier frequency. This would produce frequencies of 800 kHz, 805 kHz and 795 kHz

### Q. Write what you know about Single Side Band (SSB) transmission?

At full modulation the carrier in an AM signal requires two thirds of the power but conveys no information. The second side band can be viewed as redundant (overlooking frequency-selective fading in an ionospheric transmission path, that may distort one side band at times). Interference between several carrier frequencies, resulting in steady audio whistles or 'beats' is another disadvantage of AM.

Power may be saved and the band occupied by an AM signal in the frequency spectrum can be halved if only one side band is transmitted without carrier. The result is single side band suppressed carrier signal, called simply single side band signal (SSB) transmission.

The carrier must be reintroduced at the receiver in such systems and closely adjusted to the original carrier frequency to avoid signal distortion. The introduced carrier must be within 10 or 20 Hertz of the original carrier frequency for adequate intelligibility of voice signals, and stable oscillators are needed for generation of the local carrier.

For SSB the transmitter does not need to generate carrier power, and ratings are in terms of peak-envelope-power (PEP), the power capability at the peak of the modulating signal with linearity of the amplifier is maintained. For equal information content, and 100% modulation, the SSB signal requires only  $\frac{1}{6}$  th power of the double side band signal. However, the situation is even more favourable to SSB when speech is transmitted. Speech is not a continuous sine wave, and its average power is low with respect to its peak requirements. A peak-to-average power ratio of 10:1 is often assumed for speech, and under that condition, a Double Side Band (DSB) AM signal would require 1.05 times carrier power, whereas for equal intelligibility the SSB signal would require only 0.05 units of power or  $\frac{1}{21}$  as much.

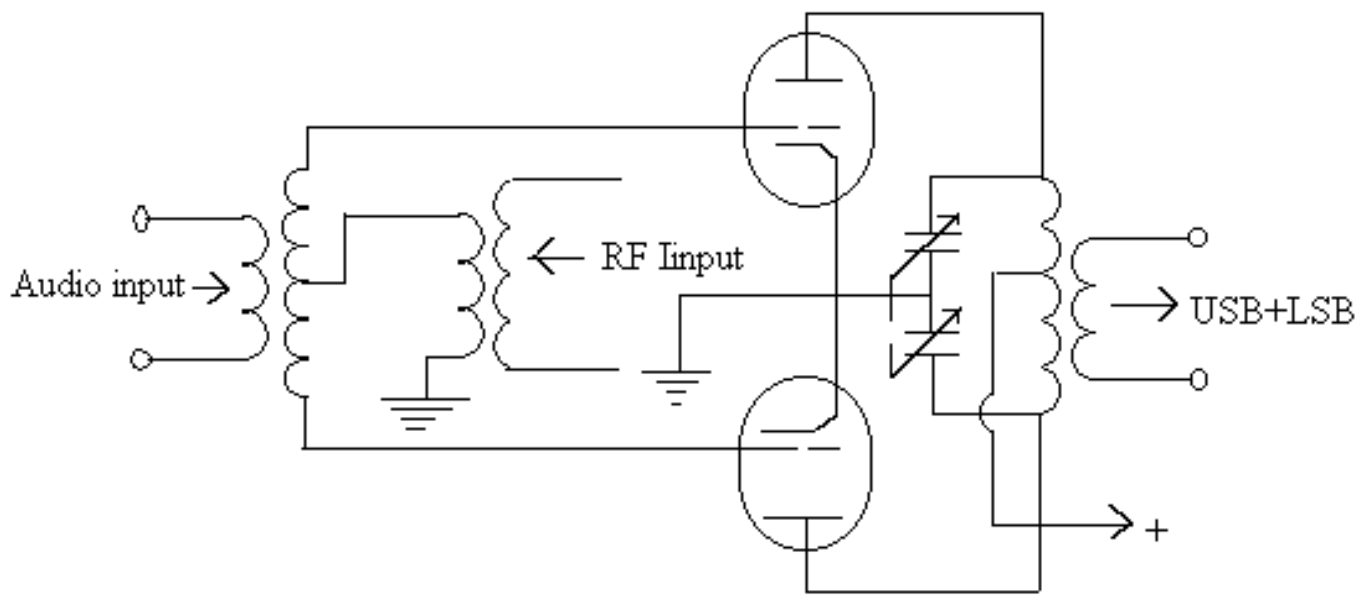

A balanced modulator circuit using valve

Because of the lower power rating, circuit components designed for SSB equipment can be smaller and lower in cost.

For generation of a modulated signal without carrier, a balanced modulator is used. A filter then discards one side band.

**Q. Why 100% modulation should be aimed in voice transmission?**

The power of a modulated wave is found from the formula:

$$P_{\text{mod}} = (1 + m^2/2) \times P_{\text{carr}}$$

Where  $P_{\text{mod}}$  = Power of the modulated wave,

$M$  = degree of modulation,

$P_{\text{carr}}$  = power in the carrier frequency.

The power in an amplitude modulated wave is divided between the carrier and the two side bands. The carrier power is constant, and so, the side band power is the difference between the carrier power and the total power in the modulated wave. The above formula is to find the power of the modulated wave when carrier is modulated by single sinusoidal tone.

If the carrier power = 50 watts

%ge of modulation = 100 or 1

degree of modulation = 1

Then the power of the modulated wave,

$$P_{\text{mod}} = (1 + m^2/2) \times 50 = 3/2 \times 50 = 75 \text{ watts}$$

Since the carrier power = 50 watts; the two side bands have 25 watts in them, i.e.

$$25/75 \times 100\% = 33.3\% \text{ of the total power with 100\% modulation.}$$

In case of 50% modulation with same carrier power we have,

$$P_{\text{mod}} = (1 + 0.5^2/2) \times 50 = 2.25/2 \times 50 = 56.25 \text{ watts}$$

Now the side bands have only 6.25 watts (since  $56.25 - 50 = 6.25$ )

Since all the intelligence being transmitted is contained in the side bands, the desirability of a high percentage of modulation is crystal clear. A comparatively low powered, but well modulated transmitter often produces a stronger signal at a given point than does a much higher powered, but poorly modulated, transmitted the same distance from the receiver.

**Q. Draw the schematic diagram of your intended transmitter and explain its function in brief.**

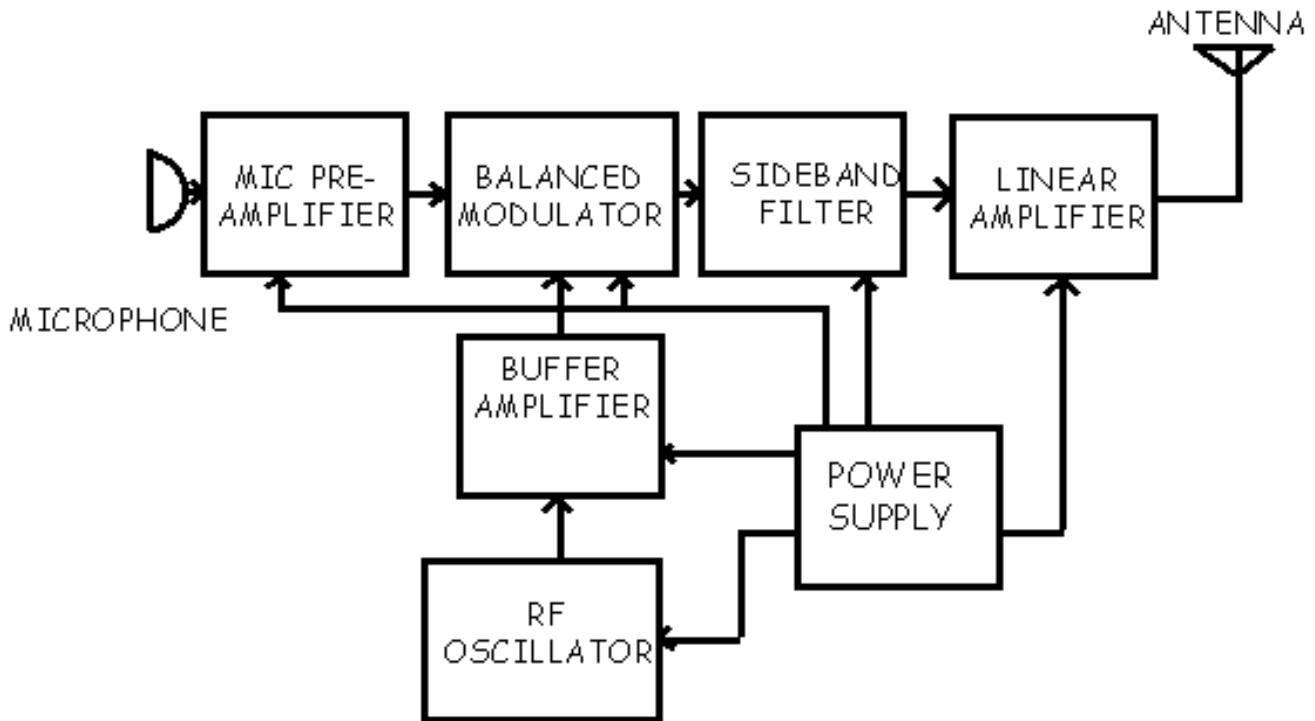

### RF Oscillator

This is the stage where the carrier frequency intended to be used is generated by means of Crystal Oscillator Circuitry or capacitance-inductance based Variable Frequency Oscillator (VFO). The RF oscillator is designed to have frequency stability and power delivered from it is of little importance, hence can be operated with low voltage power supply with little dissipation of heat.

### Buffer Amplifier

The low power RF carrier output from the RF oscillator is amplified in this portion and it also keeps the RF oscillator and power amplifier circuits separate electrically imparting frequency as desired by the amateur can be done in this stage, when the carrier frequency multiplication technique is applied here. In it the Morse key for keying out carrier continuous wave can be accommodated.

### Modulator

Audio information is impressed upon the carrier frequency at this stage.

### Balanced Modulator

In this type of modulator, while the audio information (voice) is impressed upon the carrier frequency, at the same time its output gives a signal without carrier frequency but yet with the two side band frequencies carrying the voice/audio information.

### Side-band filter

It discards out any one of the side band.

### RF linear Amplifier

RF power amplification is done here and this stage is coupled to the antenna system through antenna impedance matching circuitry. Care is taken at this stage so that no harmonic frequency is generated which will cause interference in adjacent band (splatter) on other bands.

### Q. Why crystal oscillators are used and where?

Crystal oscillators are used in most modern commercial radio transmitters, either telegraph or telephone. Quartz crystal oscillators are used because they do not drift more than a few hertz from the frequency for which they are ground. A variable Frequency Oscillator (VFO) tends to drift considerably more.

### Crystal Oscillators

Crystals made from quartz are used in radio frequency oscillator circuits in order to impart stability to the frequency of oscillation. The function of the quartz crystals are based on the piezoelectric effect, i.e. generation of electricity by compressing or stretching the quartz. Conversely the quartz crystal can be made to expand or contract physically by applying a voltage across it (e.g. by placing it between two metallic plates where the voltage is applied).

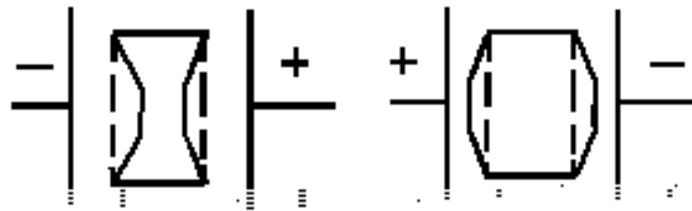

Expansion and contraction of a crystal

At its resonant frequency a crystal behaves exactly like a tuned circuit. If a crystal between metal plates is shock-excited by either a physical stress or an electric charge, it will vibrate mechanically at its natural frequency for a short while and at the same time produce an ac emf between the plates. This is somewhat similar to the damped electron oscillation of a shock excited LC circuit.

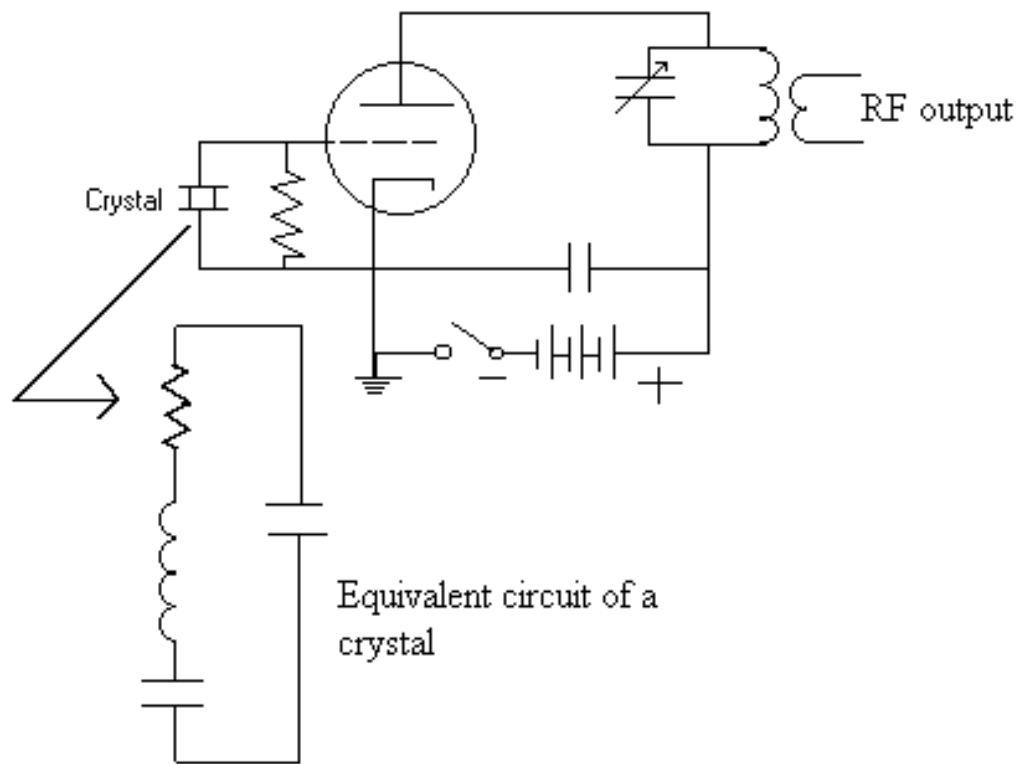

A Tuned Plate Tuned Grid (TPTG) circuit

The circuit shown is a TPTG (Tuned Plate Tuned Grid) circuit. When the switch is closed, the LC (Inductance-Capacitance) tank in the plate circuit is shock-excited into oscillation by the sudden surge of plate current. The ac developed across this LC circuit is fed back to the top crystal plate through inter-electrode capacitance, and to the bottom plate of the crystal through the bypass capacitor from the LC circuit. The crystal starts vibrating and working as an ac generator on its own. The emf generated by the crystal, applied to the grid and cathode, produces plate current ( $I_p$ ) variations in the plate LC circuit. With both crystal and LC circuit oscillating and feeding each other in proper phase, the whole circuit oscillates as a very stable ac source. The plate LC circuit must be tuned slightly higher in frequency than the crystal to produce the required phase relationship between the two circuits to sustain oscillations.

## F. Radio Wave Propagation

### Q. Write a note on Radio Wave Propagation

Short wave or **High Frequencies (HF)** in the range of **3-30 MHz** propagates through an invisible layer which consists of charged particles located at altitudes of between 250 and 400 km in the atmosphere surrounding the Earth. This layer of charged air particles called  $F_2$  layer of the ionosphere plays a vital role in HF propagation by reflecting or refracting the HF signals back to Earth.

The ionosphere has got different sub-layers. The lowest is **D-layer** at altitudes ranging from 50 to 90 km. **High frequencies** (3-30 MHz) penetrate this layer, while low frequency (LF: 30-300 kHz) or medium waves are absorbed by this layer. To some extent LF and Very Low Frequency (VLF: 3 to 30 kHz) are reflected during daytime. It slightly scatters and absorbs HF. This layer subsists only during daytime.

The **E-layer** extends from an altitude of 100 km. Though sunlight is an important factor for its existence, after sunset also it exists for some time. This layer is responsible for evening and early night time propagation of medium waves up to a distance of about 250 km. Propagation of lower short wave frequencies, e.g. 2 MHz, up to distance of 2000 km at daylight time is due to this layer. It has little effect at night.

**F<sub>1</sub>** layer exists at an altitude of 200 km during daytime and its characteristics are very similar to E-layer which merges into F<sub>2</sub> layer at night.

**F<sub>2</sub> layer** is the most important layer, which exists at altitudes ranging from 250 to 400 km and HF long distance propagation round the clock is due to this layer. The behaviour of this layer is influenced by the time of the day, by season and by sunspot activity. F<sub>2</sub> layer was formerly known as Appleton layer. This layer has a high ionization gradient. This layer exists both in the daytime and nighttime. Since at such an altitude air density is extremely low, the free ions and electrons (due to the action of ultraviolet radiation from the Sun) can not recombine readily and so can store energy received from the Sun for many hours; that is the reason the refractive property of this layer changes only to a negligible extent during day and night. The path which the short wave signal follows through the F<sub>2</sub> layer is in reality a curved one. Degree of the curve depends on the angle of incidence of the wave, ionization gradient of the layer and frequency of the signal.

### **Q. What is skip distance?**

As discussed above, under the action of solar radiation (and the hail of meteorites), an ionized layer is formed in the upper part of the Earth's atmosphere. In this layer, the neutral air molecules are decomposed into ions and electrons and the whole layer presents a chaos of charged particles. Short wave radio signals are reflected from this layer just as light rays are reflected from the surface of a mirror, or sound from a barrier. Likewise, this layer can be compared with the edge of billiard table: if the ball does not go straight into the pocket, it can be sent on rebound. In a situation a radio receiver located at a distance of 200 kilometers away from the wireless transmitting station can not receive signals from the transmitting station, but another receiving station which is located even at a distance more than this distance can copy the signal. **This is because the ground waves are stopped by the Earth's curvature and the sky wave will not reach the receiver**, because it bounces again more than 200 kilometers way. So some '**blind zones**' are formed and if the receiver is located in that blind zone it will receive no signal or very weak signal. In such a situation, another station can relay the message to the target station. The distance of the intended receiver from the transmitter is then termed as '**skip distance**'. So it is not always necessary that a receiving station located near to the transmitting station will be able to receive its signal.

### **Q. How do the hams overcome the variable propagation conditions of the ionosphere and the problem of skip?**

The problem of variable propagation conditions can be partially overcome by using frequency diversity, in which an allotted communication network is provided with several frequency assignments spanning the High Frequency (HF) band of frequencies. The ham can choose the frequency that gives the best results at any given time. Similarly if a station is in skip at a particular frequency, another workable frequency can be found out.

### **Q. What is line-of-sight propagation?**

The radio frequencies above 30 MHz has the tendency to penetrate the ionosphere making them unsuitable for long distance propagation. So, the range of frequencies from **30 to 300 MHz** (also 300 MHz and above), which are placed under the **Very High Frequency** (VHF) category are mainly used for line-of-sight communication. The most common example of line-of-sight communication is the TV Telecast.

A TV transmission tower is made as tall as possible so that its signals can have a wide area of coverage. To receive a TV telecast, we have to turn our TV antenna (known as a Yagi antenna) towards the TV transmission tower. In areas where the TV transmission tower is located at a far away place from a viewer, the viewer has to increase the height of his TV receiving antenna.



This means that both the transmitting and receiving antenna should literally see each other to make the communication effective. Otherwise there should be some means to redirect the signal back to the receiver. Artificial Satellites in space (which houses active electronic relaying device), terrestrial relay station and passive reflectors (the metallic plates we see above the hills) are employed to extend the VHF coverage. Line-of-sight communication is considered reliable within a short distance (or even for long distance communication if artificial communication satellites are employed), because instead of relying on the ionosphere (whose propagation conditions are not under human control), relay stations (known as repeater station) can be set up on tall towers. The relay station can cover a certain area most reliably round the clock. Different services employing VHF for communication also have their own repeater station. Another advantage of VHF is that the size of the VHF equipment is very small

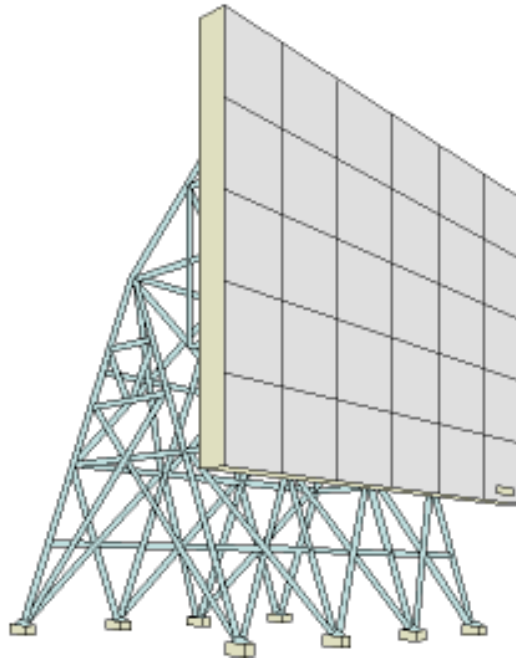

**A Passive reflector**

(because of its low power as well as miniaturization in the circuit design). A VHF communication set is also popularly known as a Walkie-Talkie. We are certain that the above description is sufficient to clear any doubt about the range of a Walkie-Talkie !

**Q. What are the two phenomenon significant in line-of-sight reception?**

In case of line of sight reception, there are **two components** of the signal. One is the **direct signal** and other is **the signal reflected from the ionosphere**. Both the signals leave the antenna with the same signal phase, but travel different paths to the receiving antenna. These paths may be of different length. Because the reflected signal **suffers 180 degree phase reversal** at the point of reflection, the two signals may **aid or oppose** each other in the receiving antenna. The resultant signal may be stronger or weaker than the direct path signal alone, which is not desirable.

**Q. How can you overcome the problem caused by this phase reversal phenomenon?**

The problem arising out of the undesirable phase reversal phenomenon can be overcome by varying the height of the antenna.

**Q. What is temperature inversion phenomenon as applicable to the line-of-sight communication?**

The line-of-sight propagation is limited to the optical horizon and it is only about 75 miles for frequencies above 30 MHz; but it is found that in the spring or fall, or sometimes in summer, this line-of-sight propagation extends to about 500 miles. This is due to the presence of layer of hot, dry air above a layer of cool, moist air. The direct waves are bent back which otherwise pass over the receiving antenna.

### **Q. What is 'grey line' propagation as applicable to line-of-sight communication?**

It has been observed that around sunspot maximum years at about 11-years intervals, the daytime F<sub>2</sub> layer, roughly 200-400 miles above the surface of the Earth, can often open long distance paths of frequencies up to and beyond 50 MHz. In periods of low sunspot activity very few long-distance paths are open above 25 MHz. Radio amateurs, whose transmitters are so much less powerful than those used for broadcasting, have come to recognise the importance of what is called '**grey line**' propagation. This takes the form of reliable but brief long-distance paths that open between places where the times of dawn and dusk, dawn and dawn or dusk and dusk roughly coincide, giving rise to the possibility of extended 'one-hop' propagation due to layer entrapment brought about by tilts in the F-layer, as the lower F<sub>1</sub> and higher F<sub>2</sub> layers combine or separate.

### **Q. What is a critical frequency?**

The whole spectrum of radio frequencies suffer various degrees of refraction by the ionosphere. Waves which are very slightly refracted can not return back to the Earth and if not having adequate power, get absorbed into the ionosphere. Those having sufficient power can penetrate the ionosphere depending upon the degree of refraction. The amount of refraction is inversely proportional to the frequency of the wave. Obviously, lower the frequency, greater is the refraction and higher the frequency, lower is the refraction. Though a greater refraction should cause the frequency to be returned back to Earth, it does not happen always. During day time, the D layer (It is the lowest region of the ionosphere at a height of about 60 to 90 km. It is not strictly a layer but a relatively dense part of the atmosphere where atoms are broken up into ions by sunlight that recombine very quickly) absorbs most of these waves prohibiting their entry into the E and F layers and hence does not get reflected. If the frequency of a wave transmitted directly upward is steadily increased, a point would be reached where the wave would pass right through the ionosphere. The frequency at which this occurs is called the *critical frequency*. All frequencies higher than this will not be returned to Earth.

### **Q. What is a beacon?**

The beacon is nothing but a radio signal, usually in coded form transmitted from a particular station to identify itself. The usefulness of the beacons is that they provide indication of propagation conditions between any two locations worldwide. They also act as in-band frequency reference for wireless experiments experimenting with transmitters. They also provide reliable checking facility for beam antennae.

### **Q. What is the difference between Fade-out and fading?**

#### **Fade-out**

It is the gradual phenomenon, that take place with the change of time of the day. Fadeout of radio signal is related to the ionization gradient of the ionosphere, which decreases in absence of sunlight. Since ionization is intense during day light hours, higher frequency (like 14 MHz and 21 MHz) of the short wave spectrum can be used during daylight hours. As the night approaches, signal strength at that higher frequency decreases. Using a frequency at the lower edge of the HF spectrum (e.g. 7 MHz) will yield satisfactory result against this fadeout.

#### **Fading**

As distinct from fade-out, fading is the constant variation of the received strength of radio wave. To the listener it appears as gradual rising and falling of the volume. The signal waxes and wanes and at times even drops below usable values. This phenomenon is manifested chiefly in long-distance transmission. It is caused by multiple reflections from the ionosphere which cause two or more waves from the same transmitter travel over different paths of different lengths and hence differ in phase and amplitude when they arrive at the receiving aerial.

## G. Aerials

### Q. Write a general note on aerials.

Aerial or antenna is a device, which acts as the mouth and ear of a radio transmitter or receiver respectively. Though we don't notice any external aerial in many of the commercial radio sets, they in fact, have aerials in built within the cabinets holding their electronic circuitry. But a ham radio operator is mainly concerned with an external outdoor antenna without which he can't expect to radiate radio energy into space from his radio transmitter. Similarly, without an external outdoor antenna, his radio receiver will not be able to pick up the radio waves speeding across the sky. A radio receiver might not need an external outdoor aerial to receive high power radio transmissions. But most of the ham radio transmitters use considerably low power (compared to the broadcast radio stations) which necessitates the use of outdoor aerials. A low power transmitter with an efficient antennae system or a less sensitive receiver with efficient antennae system can be made to work beyond imagination!

The aerials are usually made out of metallic rods or wires which are cut into specific lengths. The aerial should not be placed behind any obstruction. Conducting materials such as tin-roof, ferro-concrete and to lesser extent foliage when wet. The aerial should be as high as practical above the ground and grounded objects such as metal roofs, power or telephone wires etc.

### Q. What are the different types of antenna system used by ham radio operators?

Different types of antennae system commonly used by ham radio operators are:

1. Horizontal Dipole,
2. Inverted -V dipole,
3. Yagi beam,
4. Ground plan vertical,
5. Qubical quad

### Q. Describe the working function of a horizontal dipole antenna.

A horizontal dipole antenna is a resonant antenna which is half-wavelength long. Resonant circuits are well known in radio engineering as combination of coils and capacitors, which cause a signal gain at certain frequencies. The same is applied to a half-wave dipole antenna.

It consists of two straight wire or rod sections, each  $\frac{1}{4}$  wave long and positioned in one line (collinear). The antenna is fed in the centre by a coaxial cable having a characteristics impedance of 50 Ohms or 75 Ohms.

The maximum radiation direction is perpendicular to the axis from the middle point. The cause of directional radiation by a resonant  $\frac{1}{2}$  wave dipole antenna is that the radiation intensity is proportional to the square of the current in the antenna, and in the dipole current is maximum at the middle; hence the maximum radiation line

passes through the middle of the antenna perpendicularly.

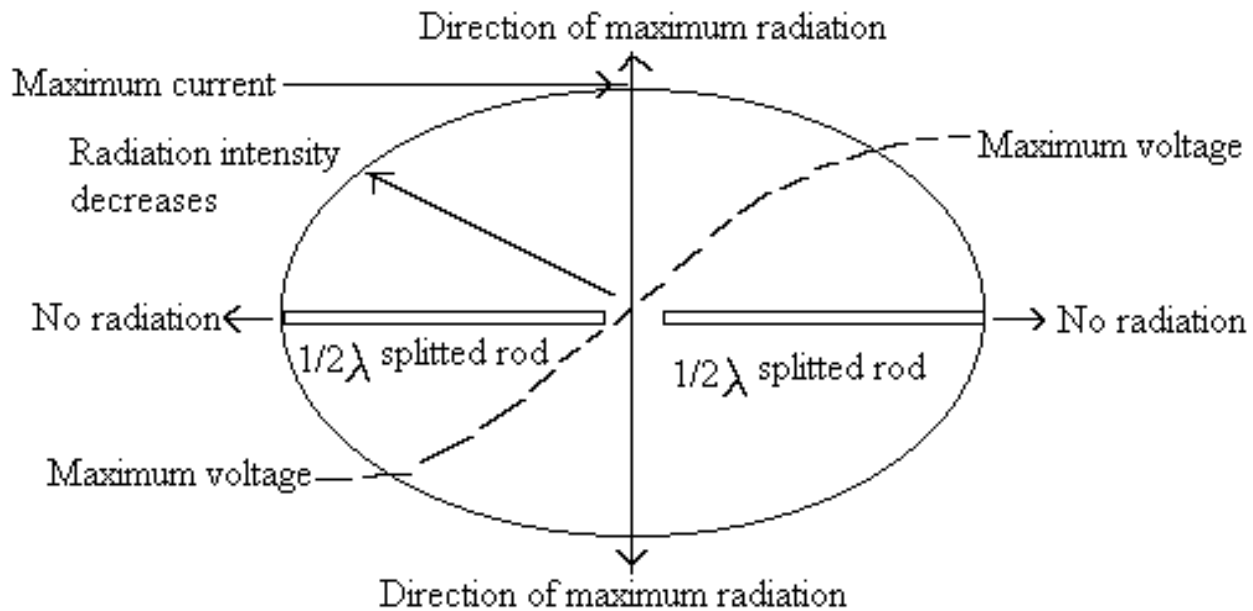

### Characteristics of a half wave dipole antenna

#### Q. Why half-wave dipoles are fed at the centre?

Most half-wave dipoles are fed at the centre, because in a half-wave resonant dipole, maximum current point is at the centre of the antenna and this is the minimum voltage point. It is easier to construct transmission lines for low voltage than for high voltage.

The other reason is that in a  $1/2$  wave dipole, the capacitive reactance and inductive reactance cancel each other (the antenna being resonant), leaving resistance only as net impedance. Under this condition, the antenna impedance is the resistance between any two points equidistant from the centre along the antenna length making it easier to match the transmission line impedance with the antenna impedance.

#### Q. What is VSWR (Voltage Standing Wave Ratio) ?

When the transmission line does not match the load impedance (antenna impedance), maximum transference of energy to the antenna is not possible. The energy fed down the line is transferred to the antenna only partially; in fact, some is reflected back, forming standing waves on the line. Every half-wave along the line, high-E (Voltage) and Low-I (Current) points appear. Halfway between these two points will be Low-E and High-I points.

The ratio of voltage across the transmission line at the high-E point to that at Low-E points is called the VSWR.

$$VSWR = \frac{E_{\max}}{E_{\min}}$$

Or,

$$SWR = \frac{I_{\max}}{I_{\min}}$$

The SWR is also equal to the ratio of the characteristic impedance of the transmission line to the impedance of

the antenna (load), or vice versa. For example, if the line has a characteristic impedance of 300 ohms and antenna impedance is 50 ohms, the SWR is 300/50, or 6. A higher SWR indicates a greater mismatch between the transmission line and the antenna.

When the load (antenna) impedance matches the transmission line impedance, there will be no standing waves.

SWR=1:1 or 1

VSWR is greater than one for a mismatched system and equal to one for a perfectly matched system.

VSWR on a transmission line is caused by power being reflected back to the transmitter from the antenna. If  $P_F$  is the forward power and  $P_R$  is the reflected power measured in watts by a directional wattmeter, then VSWR can also be calculated by the formula:

$$VSWR = \frac{1 + \sqrt{P_R / P_F}}{1 - \sqrt{P_R / P_F}}$$

### **Q. What is 'radiation resistance'?**

When an antenna is excited into oscillation by a RF source, it radiates energy into space acting as a source of power. The antenna, which is the source of power must have an internal resistance or impedance.

We have-

Power,  $P=I^2R$ , Where I=current, R=resistance

Or,  $R=P/I^2$

So in case of the antenna, radiation resistance is the ratio of the radiated power to the square of the centre current in the antenna.

Radiation resistance is also defined as a fictitious resistance, which when substituted for the antenna would consume as much power as the antenna radiates.

Radiation resistance is also called 'Feed-point' impedance; in case of a dipole antenna feed point impedance is nearly 73 Ohms.

### **Q. Why impedance matching is necessary in an antenna and transmission line system?**

Impedance matching is of utmost importance so far as energy transference from the transmitter to the antenna through the transmission line is concerned; because, mismatching will prevent maximum output being radiated, i.e. if the transmission line impedance doesn't match the antenna feedpoint impedance, a part of the energy fed down the line will be reflected back from the antenna causing standing waves on the line; it makes the system inefficient.

Mismatching a transmission line to an antenna results in the line at the transmitter end appearing to have either inductive reactance ( $X_L$ ) or capacitive reactance ( $X_C$ ), which will detune the inductance-capacitance (LC) circuit to which it is coupled; mismatching should be avoided so that final stage of the RF amplifier is not detuned.

In many of the commercial wireless equipment, mismatching should be strictly avoided to prevent damage of the circuitry.

### **Q. What are current fed and voltage fed antennae?**

## Current fed antenna

There are many methods of feeding energy to an antenna. The antenna is said to be current fed when excitation energy from the RF-generator is introduced to the antenna at the point of high circulating currents. The example is a  $1/2$  wave dipole antenna. In this case, the  $1/2$  wave antenna is cut in two parts at the midpoint and energy is fed by co-axial transmission line.

In a dipole antenna maximum current flows through the middle point, hence it is current fed antenna with a characteristic feed point impedance of about 73 ohms, which is considerably small as compared to end point impedance of the antenna. Midpoint is the low-voltage point.

## Voltage fed antenna

When the excitation energy from the RF source is introduced at the point of maximum voltage, the antenna is said to be voltage fed antenna. The example is the  $1/2$  wave unsplitted antenna excited by a resonant R-F line. Voltage changes at this point excite the antenna into oscillation. The impedance at the end of the antenna is high or it is the high impedance point.

Any multiple of a  $1/2$  wave resonant antenna may be end-fed by using a tuned feeder system leaving one end of the feed-line unconnected. This antenna is also called Zepp (used earlier on Zeppelins) antenna.

## Q. Write about different types of antenna system impedance matching procedure.

- . Using the **proper transmission line** for each particular antenna is a way of achieving impedance matching. For example, a  $1/2$  wave dipole has a midpoint impedance of 73 ohms, so coaxial cable transmission line which has a characteristic impedance of 75 ohms is used to feed the R-F energy into the antenna.
- b. Delta match:** This type of matching procedure is used with an unsplitted  $1/2$  wave dipole antenna; the dipole being resonant, its capacitive reactance ( $X_C$ ) and inductive reactance ( $X_L$ ) cancel each other, leaving resistance only as net impedance. Under this condition, the antenna impedance is the resistance between any two points equidistant from the centre and thus transmission lines having characteristic impedance of 300 to 600 ohms be used by getting two points of the antenna to feed where it offers a feed point impedance equal to transmission line impedance.

To do so, it is essential to spread out the feeders at the antenna end.

The formula used to make this type of matching are :

$B = (0.25 \times \text{Wavelength})/2$ ; where B is the distance between the two feed point which will offer 600 ohms impedance.

And  $C = (0.32 \times \text{wavelength})/2$ , where C is the vertical distance upto which spreader should be spread (the inclination).

- c. Stub Match :** A shorted stub of  $1/2$  wave length or open stub of  $1/4$  wave can be connected to the splitted dipole. Here the low midpoint impedance of 73 ohms of the dipole is repeated at the close end of the stub; but there are certain points on the stub which would offer as high as 600 ohms impedance yet matching with 73 ohms feed point.
- d. Gamma Match:** Here outer sheath of the 75 ohms coaxial cable is connected to the middle point of the unsplitted dipole, while the inner conductor is connected to a point through a capacitor to cancel inductive reactance, so that antenna impedance at feed point is 75 ohms. Gamma match is slightly unbalanced.

- e. **T-Match:** In this type of impedance matching, two coaxial cables are held side by side and both their outer sheaths are connected to the midpoint of the unsplitted dipole, while two points are chosen on the dipole where inner conductors going parallel to each other (of the coaxial) are connected.
- f. **1/4 wave transmission line impedance matching device:** A 1/4 wave line can act as an impedance matching device between high and low impedance circuits if it has the proper intermediate impedance found from the formula:  $Z = \sqrt{Z_1 \cdot Z_2}$

Where  $Z_1$  = antenna feedpoint impedance;  $Z_2$  main transmission line impedance. When we want to match a 300 ohms transmission line to a 70 ohms feed point impedance dipole antenna, then the 1/4 wave transmission line connected between both the system should have

$$Z = \sqrt{300 \times 70} = 145 \text{ ohms}$$

### Q. What is a Yagi antenna?

When a half wave dipole antenna consists of one or more parasitic arrays, the antenna becomes parasitic beam antenna, named as "Yagi" after its designer Proff. Yagi, Japan.

The antenna consists of mainly three elements, the 1/2 wave splitted dipole driven element, in front of this driven element is the 5% shorter director element, back of the driven element is the 5% longer reflector. All the elements can be assembled on a single conducting boom. This antenna beams radio signals in the direction of the director and no signals to the backward direction.

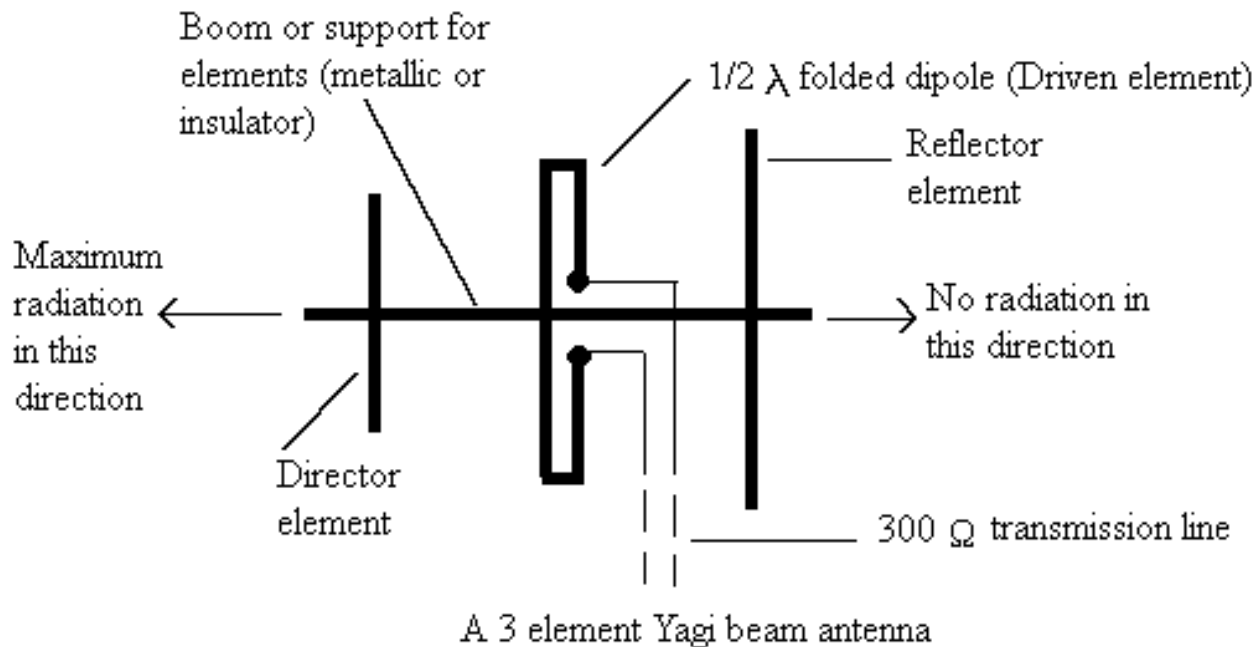

### Part-IV

#### Study material to learn Morse Code

## The International Morse Code

The telegraphic code used for amateur radio telegraphic communication is the International Morse Code consisting of dot (.) and dashes (-). In Morse Code a dot (.) is made by pressing the telegraph key down and allowing it to spring back up again rapidly; and for making a dash (-), the key is held down for a bit longer period. It is said that a dash(-) unit is three time longer than a dot(.) unit. The Morse Code in fact consists of combinations of aurally distinguishable tones. A tone produced for short duration is a dot tone and a tone three

times longer than this tone is a dash tone.

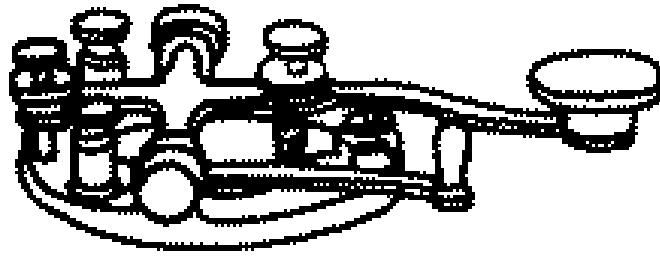

A Morse Key

To practice Morse Code sending, a novice can use a small device called the 'Code Practice Oscillator' (CPO). This is a small electronic circuit capable of generating a sinusoidal audio tone when a key (or switch) is made 'on' or 'off' manually. The circuit of a CPO shown below can be easily assembled by a novice.

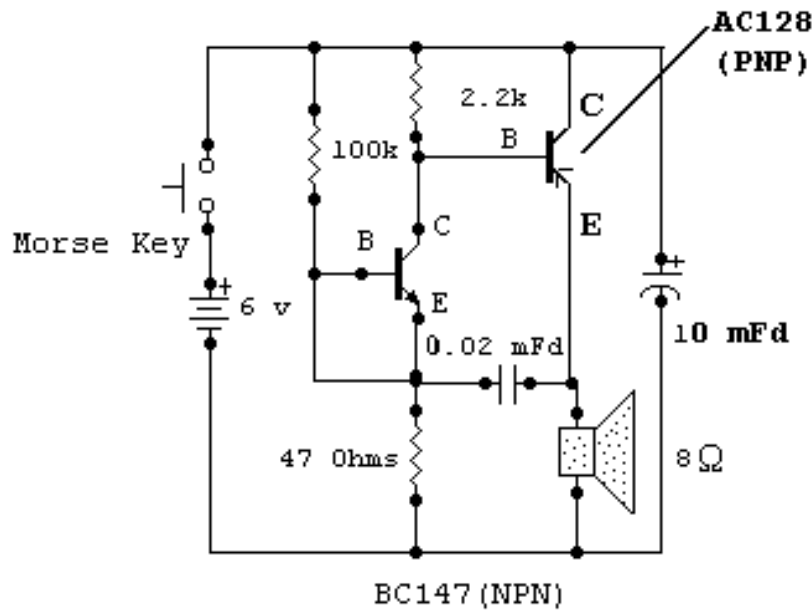

A Code Practice Oscillator (CPO) circuit

It is advisable not to start practice sending the Morse code until the novice is proficient in receiving Morse code. For receiving practice, you have to rely on a ham radio operator who can send/generate Morse code using a CPO or you can try to find out Morse Code transmissions over your radio receiver. Morse code practice cassettes and multimedia computer software are nowadays available. Mere gaining confidence in sending does not qualify you to be an expert receiver! In fact you may not be able to receive a single letter in Morse code even if you gained a sending proficiency of 12 words Per Minute (WPM)! Remembering the Morse codes is an art by itself. It involves a rhythmic response in your mind. Try to remember the combination of dot (.) and dashes (-) by their sound and not as a group of printed symbols. For this purpose, a dot (.) is referred to as a 'di' and a dash (-) as a 'dah'. A 'di' coming at the end of the combination is pronounced as 'dit'

The letter 'R' is represented by '. - .' (di dah dit) in Morse code. The time taken to produce the sound equivalent to one 'di' or 'dit' (dot) is taken as unit time and called a dot unit. A 'dah' is approximately of three dot units length and the space between two sound elements of a letter is one dot unit, i.e. silence period is one dot unit. The space between two letters or characters is equal to three dot units. The space between two words is equal to five dot units. The word 'cat' can be represented as '-. -.' (dah di dah dit di dah dah)



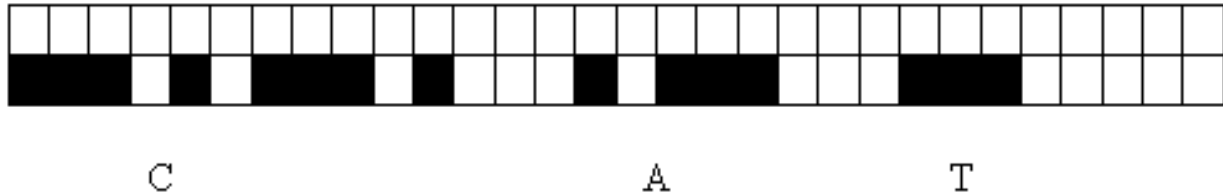

## Morse Code speed

The minimum speed to qualify for a Grade II licence is 5 words per minute (5 wpm). 5 letters/characters constitute a word. A message containing 125 letters when sent in 5 minutes or when received in 5 minutes makes your speed 5 wpm.

$125/5=25$  words in 5 minute; i.e. 5 words per minute.

In fact Morse code devised by **Samuel F.B. Morse** (1791-1872) is a primitive type of digital communication which still works efficiently in this era of microprocessors and computers. In a computer, all information are processed or stored in binary digits, i.e. 0 and 1s. A zero (0) means that the switch is off and a one (1) makes it on. One interesting fact is that any type of information can be converted to binary digits and later on the information stored in the form of binary digits can be decyphered (decoded).

In the Morse Code system, the encoding is done by 'short' and 'long' duration of flow of current through a circuit. This method of representing and manipulating information in electrical form is known as digital approach, because the encoded information may be visualized as a series of numerical digits. The modern day computer to computer digital communication (which is automated) can be visualised as an extension of the communication system that started with the hand key operated telegraphic communication (which is manual) back in 1837. The computer can sense the 'long' and 'short' pulses and decipher them automatically. But a ham receiving Morse code decipheres the message by listening to the 'short' and 'long' tones. Though the modern day computer communication has its roots in Morse code communication, yet it has been observed that the allocation of Morse codes to the characters has been done in a haphazard manner. It is believed that Samuel F.B. Morse did not visualised his code as a binary sequence. They also believe that Morse did not heard of his now celebrated compatriot **George Boole** (1854) and his famous work on binary algebra going by his name! Binary signaling is the earliest form of communication. It is defined simply as the presence or absence of a single element that when used in prearranged combinations conveys intelligence. Signal fires, reflected sunlight, smoke signals, flag waving, and jungle drums are the earliest examples of binary signaling. The earliest versions were, of course, audible or visual systems, since electrical transmission had yet to be invented. Electric signaling arrived in 1835, when Samuel Morse employed a chemical battery and a lever to send currents through a wire circuit. The original Morse machine printed code on tape. The word "telegraph" was coined to mean a device that could print patterns at a distance. It was derived from the Greek "*tele*" (far) and "*graphein*" (to write). The discovery of the "ground return" circuit meant that only one wire would be needed. Samuel Morse ushered in the age of electrical communications by sending his first public "What hath God wrought?" message on May 24, 1844 over an experimental telegraph line between Washington and Baltimore. He developed a key and sounder for this demonstration, since he discovered that the code could better be received by ear, eliminating the printer.

Morse code is also called CW, i.e. **Continuous Wave**, in the sense that a constant amplitude interrupted radio frequency wave is transmitted; interruption being made in conformity with the code.

## Analog and Digital methods

The electrical telephone and telegraph are very simple examples which illustrates the difference between the analog and digital methods. In the telephone, the information is transmitted from one end to the other via a

current which varies continuously as direct equivalent of sound waves striking the microphone-the analog approach. In the telegraph, the information is encoded (cyphered) and sent as a sequence of current/no current pulses illustrating the digital approach.

### **Why Morse code is still in use?**

It was deemed important that ham radio operators prove an ability to transmit and receive in Morse Code signals. In the last 50 years, however, the **International Telecommunication Union (ITU)** has reviewed and modified the amateur Morse Code requirement at every international conference capable of changing it. In 1947 (Atlantic City) the ITU agreed that Morse proficiency should only be required when the operation took place on frequencies below **1000 MHz** (1 GHz). At WARC-59 (The 1959 World Administrative Radio Conference) this level was dropped to **144 MHz**. A further reduction was made at WARC-79 to its presents **30 MHz**.

Despite the capability of voice communication, Morse code is still in use. One important reason is that a vast group of the radio amateurs still adore Morse code. **A ham radio operator employing digital communication techniques (like Packet Radio, Radio Tele Typing-RTTY or AMateur Tele-printing Over Radio-AMTOR) in his ham radio operation treats Morse code with much the same affection he has for those modern innovations!**

A ham radio operator wearing his headphone and the Morse Key in hand can send messages silently without disturbing his family members who might be sleeping comfortably!

Another reason is that short wave radio telephone (voice) signals often suffer very rapid and deep fading; two frequencies separated by only a few hertz, fade at different times. To overcome this, modulated code tones are transmitted. The situation is now that under severe conditions of fading, the carrier frequency may fade out completely but one or the other side band may remain strong as a result a continuously readable signal is received. This is the reason that we hear a band full of exotic sounding CW call-signs at any time of day or night. When the a band appears to be dead, and we can barely copy phone signals, the band remains alive with many CW signals.

### **Why this be so?**

- (i) The answer is that to communicate human speech, a wider bandwidth is required than that of the CW signal. With a smaller bandwidth the 'signal to noise ratio' of the receiver is significantly improved, and the threshold at which signals can still be received above the noise level is therefore extended.
- (ii) Also, it is possible for the human ear to be able to resolve CW signals which are only marginally above the noise level, whereas SSB signals of the same signal level could not be copied. It has been suggested that CW has an advantage of approximately 20dB over SSB signals. A narrow band-pass filter improves the CW reception.

### **How to learn Morse Code?**

Many newcomers seek exemption from 'tiresome' Morse test for Short wave operation. This is unfortunate as the Morse code is the key to enter into the world of ham radio with a very little monetary investment. A novice can assemble a simple Morse code transmitter with lesser technical hurdles than that of a SSB Voice transmitter. Morse code can be learnt easily if we use certain techniques to remember the codes. Learning the Morse code can also be considered as an entirely personal venture embarked upon by alone. Following points should be kept in mind while learning the Morse code-

1. Try to remember the codes from their sound.
2. In the initial stage, you can take help of an innovative technique to memorize the different 'dot' & 'dash' combinations for each alphabet which has been devised by **A.G. Reinhold, K2PNK**, Cambridge. Bring

into your mind the image of the letter and the corresponding placement of 'dot' and 'dash' in it.

3. Don't begin with a practice to send. Sending is much easier compared to receiving.
4. During receiving of a message, don't write down the 'dot' and 'dash' combinations. Directly write down the letters in running hand. Don't bother to know the content of the message. Just continue writing the letters one by one and leave a space when you are not sure about the letter. If you wait wondering about what the letter was, you would get stuck and in the process many letters would pass by you, which you would not be able to jot down.

### THE INTERNATIONAL MORSE CODE

A . \_ J . \_ \_ \_ S . . . 1 . \_ \_ \_ \_

B \_ . . . K \_ . \_ T \_ 2 . . \_ \_ \_

C \_ . . . L . . . . U . . . 3 . . . \_ \_

D \_ . . M \_ \_ V . . . . 4 . . . . \_

E . N \_ . W . \_ \_ 5 . . . . .

F . . . . O \_ \_ \_ X \_ . . . . 6 \_ . . . .

G \_ \_ . P . \_ . . . Y \_ . \_ . . 7 \_ . . . .

H . . . . Q \_ . . . . Z \_ . . . . 8 \_ . . . .

I . . R . \_ . 9 \_ \_ \_ \_ .

0 \_ \_ \_ \_ \_

### PUNCTUATIONS

. (Period) . \_ . . . \_ (AAA)

, (Comma) \_ \_ . . \_ \_ (MIM)

? (Question mark) . . \_ \_ . . (IMI)

; (Semicolon) \_ . \_ . . . (NNN)

- (Hyphen) \_ . . . . \_ (BA)

Error sign . . . . . . . . (8 dots)

Sentence separation indicator \_ . . . . \_ (BT)

End of transmission of a message . \_ . . . (AR)

Invitation to transmit \_ . \_ (K)

Wait . \_ . . . (AS)

End of work . . . \_ . \_ (VA)

Almost all the letters/characters and punctuation marks can be arranged in certain groups which can be used to show the resemblance between/among the combination of *dot* and *dashes*. For example the letter 'A' (. \_ ) is the opposite of 'N' ( \_ . ). Similarly, the letters A, U, V and the character 4 can be made into a group which shows a

definite sequence. Given below is a table of such combinations.

A . _	T _	N _ .	E .
U . . _	M _ _	D _ . .	I . .
V . . . _	O _ _ _	B _ . . .	S . . .
4 . . . . _			H . . . .
			5 . . . . .
W . _ _	Y _ . _ _	K _ . _	P . _ _ .
G _ _ .	Q _ _ . .	R . _ .	X _ . . _
L . _ . .	Z _ _ . .	A . _	D _ . .
F . . _ .	J . _ _ _	N _ .	U . . _
	C _ . . .		
B _ . . .			
V . . . _			

EISH TMO AN DU WG BV PX

After remembering the Morse code combination for the **EISH** combination, the following words can be formed to be sent for receiving practice.

IS HIS SHE

In a similar way, once the novice is able to remember the Morse code combinations for the rest of the combinations shown above, the number of words to be sent can be increased accordingly as shown below.

THIS TOM SOME IT MISS THE

MAN NAME TEN NET HAM

DATE MAD SAD SUN

WHAT WISH SAW WET WASH GONE GOT HUG

BOSS TOMB BOMB HAVE VOTE

PET POT SHOP TAX XEROX

An innovative technique to memorize the different 'dot' & 'dash' combinations for each alphabet has been devised by **A.G. Reinhold, K2PNK**, Cambridge. This pictorial approach is reproduced below:

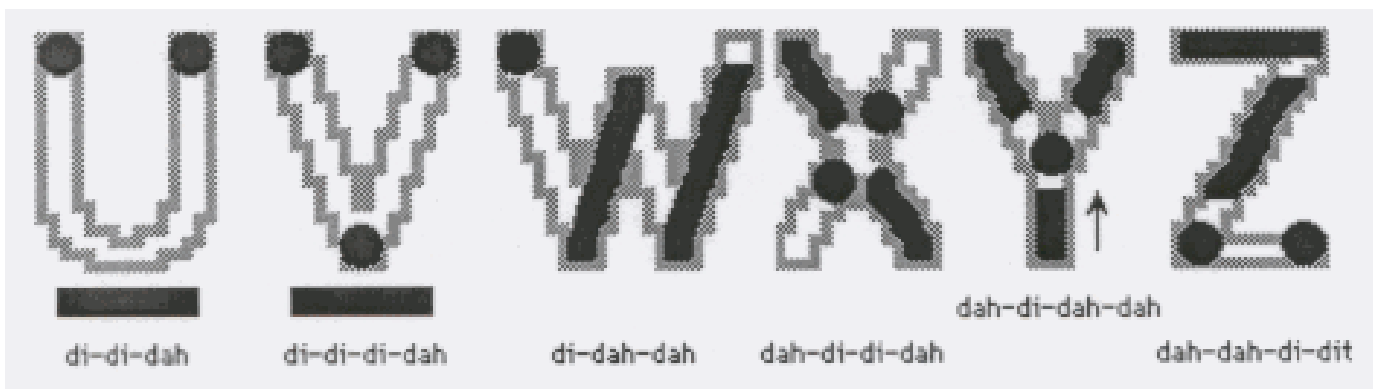
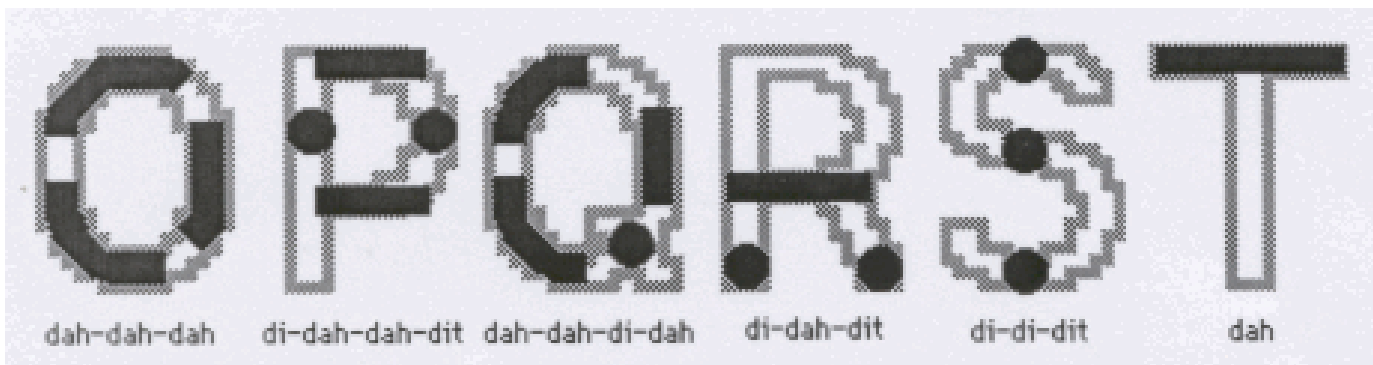
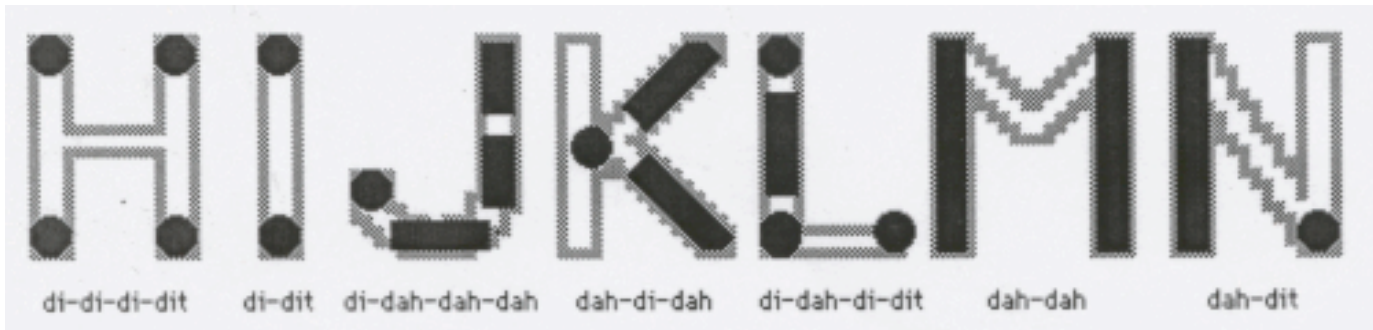
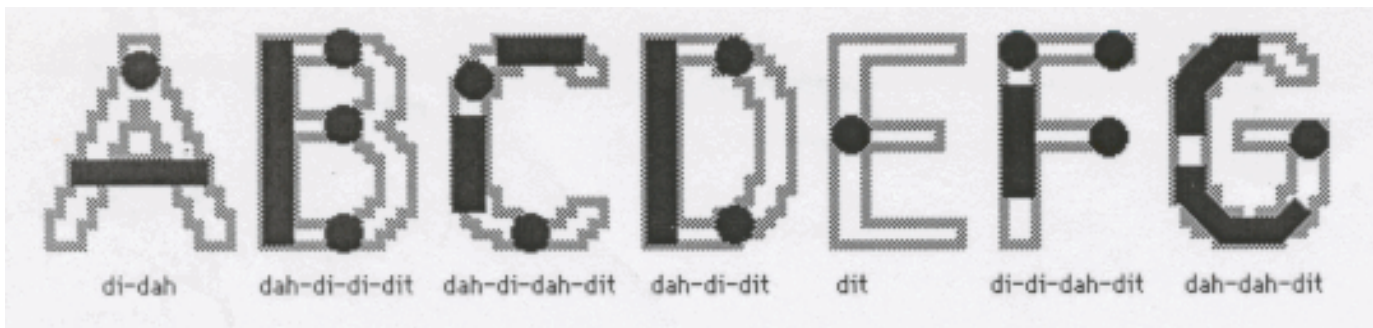

Acknowledgment : A.G. Reinhold, 14 Fresh Pond Place, Cambridge, MA 02138 K2PNK

### Part-V

## Safety measures in a ham radio shack

Electricity is one of the most magnificent discoveries that the mankind has achieved since the dawn of civilization. We are now wholly dependent on this wonder of science. Without electricity our life will become miserable and probably the life will come to a standstill. It is the backbone of an industrialized society without which progress of a society can't even be dreamt of. Functioning of all the fields of science are wholly dependant on the availability of electricity including your ham radio! While electricity has made our life full of comfort and

ease, it has also the potentiality to create heavy destruction if we do not take adequate precautions against its potential ills. A casual attitude towards the electricity should always be avoided.

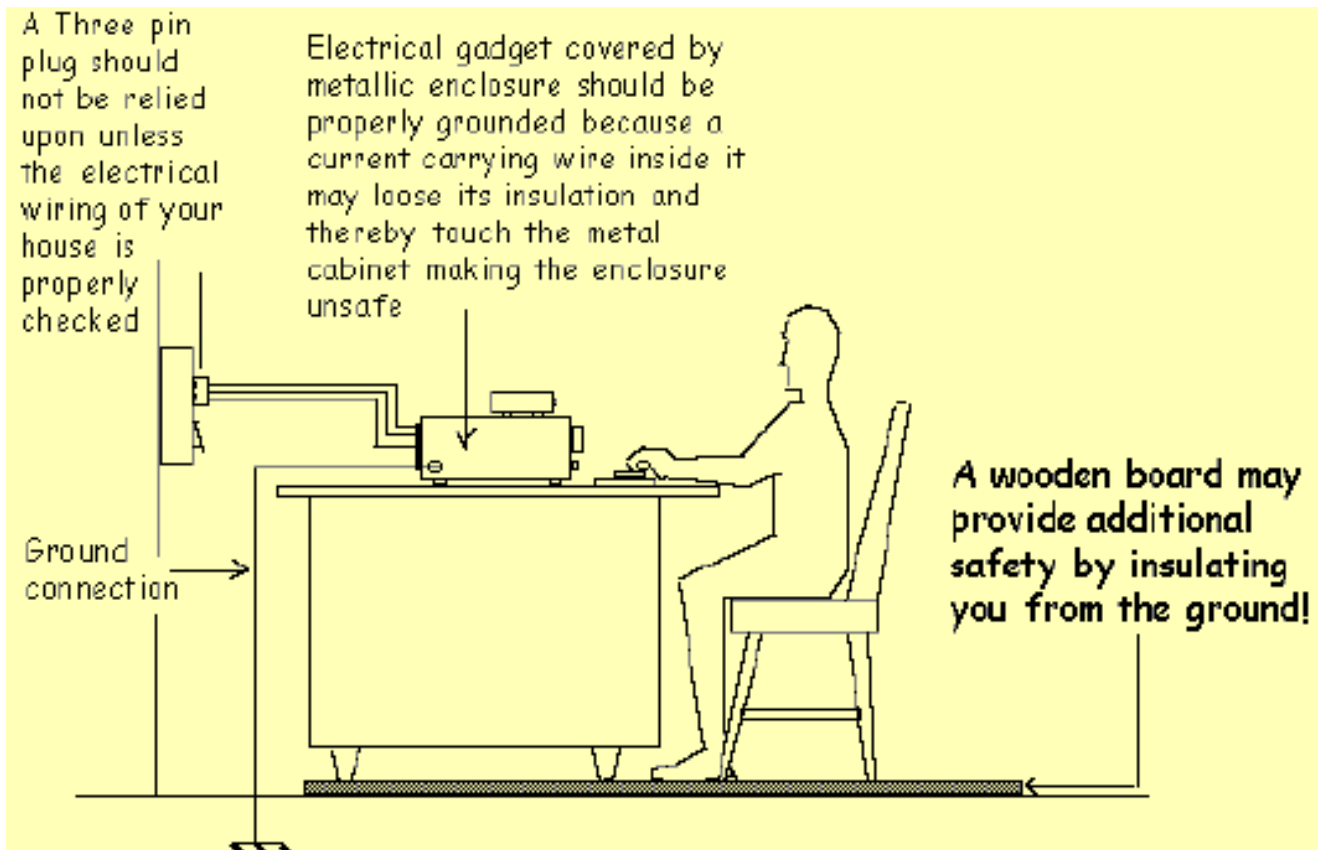

The ham should keep his wireless equipment in a protected place, so that, it can not be operated by any unauthorized person in his absence. All the equipment should be properly installed and precaution should be taken so that they don't create electrical hazards. For this and the safety of the other people in the house, equipment should have proper ground connection (an alternative path to the Earth). Though the switch board sockets have the facility to insert a three pin electrical plug (the male plug from our equipment), the wire connecting to the ground from the third hole of the socket may remain disconnected somewhere without our knowledge. This may create a risk to your life because the electrical equipment's current carrying wires are vulnerable to insulation breakdown due to many reasons.

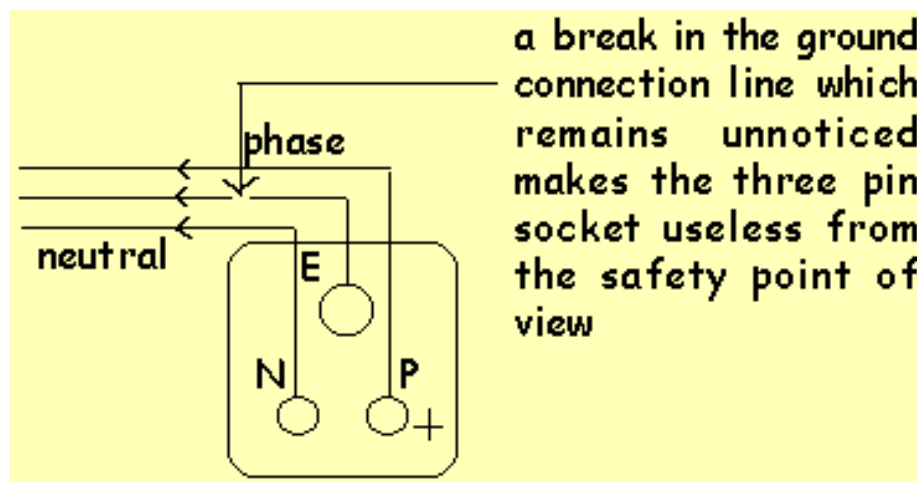

Under such circumstances, if a current carrying wire touches the metallic portion of the equipment, current will start flowing in that portion also. Under such a situation, if we touch an electrical gadget housed in a metallic enclosure, we may get electrocuted as well! In fact electrical currents seek for the paths of low resistance. In the

above situation, if we are bare footed, then these electrical currents will find their easiest path to the Earth (Ground) through our body and simulate a close circuit situation. Our body will heat up (because the human body too offers resistance to the flow of current) and we will die! In a different situation where the metallic portion of the electrical gadget is properly grounded with the help of a good conducting wire (e.g. copper), even if we touch the current carrying metallic portion, most of the current will flow through that grounded copper wire only causing less damage to our body. A part of the current will still find their path to the ground through our body because we are still bare footed! So the highest safety measure is to wear shoes made of insulated material (which do not conduct electricity) and keep us separated from the ground (the Earth). In this situation, even if we accidentally touch the current carrying metallic portion of the electrical gadget, current will not be able to find their path in to the ground through our body and we shall remain safe. In no case, the 'phase' (current carrying) and 'neutral' wires should be touched by your hand simultaneously. Doing so will create the most potential risk to your life, because, current from 'phase' to 'neutral' will now flow from one hand to the other hand (if you use both your hands to touch the 'phase' and 'neutral' !) through your body and you will be getting killed in the process!

So, always:

1. Check for **proper ground connection** in the electrical wiring of the house.
2. If possible connect an **extra conducting wire to the ground** (you can tightly tie the wire on to a water pipe) from the metallic enclosure of the electrical gadget.
3. **Don't touch electrical gadgets with wet hand.** Water reduces the resistance of the skin of our body and as a result electrical currents find their easy entry into our body!
4. Always wear **insulated shoes** (rubber, plastic etc.)
5. **A dry wooden board** can be kept on the floor which will provide additional insulation.
6. The electrical device should have a **'fuse'** as per the current rating of the device. For example, if the equipment is designed to allow a current of 5 ampere, the 'fuse' should also be rated 5 ampere. Any more current due to short circuit will blow the fuse and inactivate the equipment. This will prevent further damage of the equipment and other electrical wiring will remain safe.
7. There should be a **main switch** (called the "*Big Switch*"!) at your easy reach. While closing down your ham radio operation, this switch should be pulled to disconnect all the equipment at the same time. That is why, in ham terminology, many operator's use the phrase "*Pulling the Big Switch*" to indicate that he is closing down his station!
8. Nowadays, **miniature circuit breaker** switches (MCB) are also available. This type of switches provide safety to the electrical gadgets connected to the electrical sockets by automatically disconnecting them from the current in the event of a short circuit in the electrical wiring.
9. The **fuses in the electrical meter box should not be tempered with.** A blowing fuse indicates that an electrical gadget is drawing more current than its specification. Alternatively, you may be using too much of electrical gadgets in your house resulting in a current flow which exceeds your allotted rating. In such a situation, if you increase the thickness of the fuse wire to prevent it from frequently burning down, the whole electrical wiring of your house will be at the risk of burning down.

**This study material is prepared by Sandeep Baruah,  
VU2MUE (Ex-VU2MSY)**